

Magnetic Base Drilling Machine

E100/32

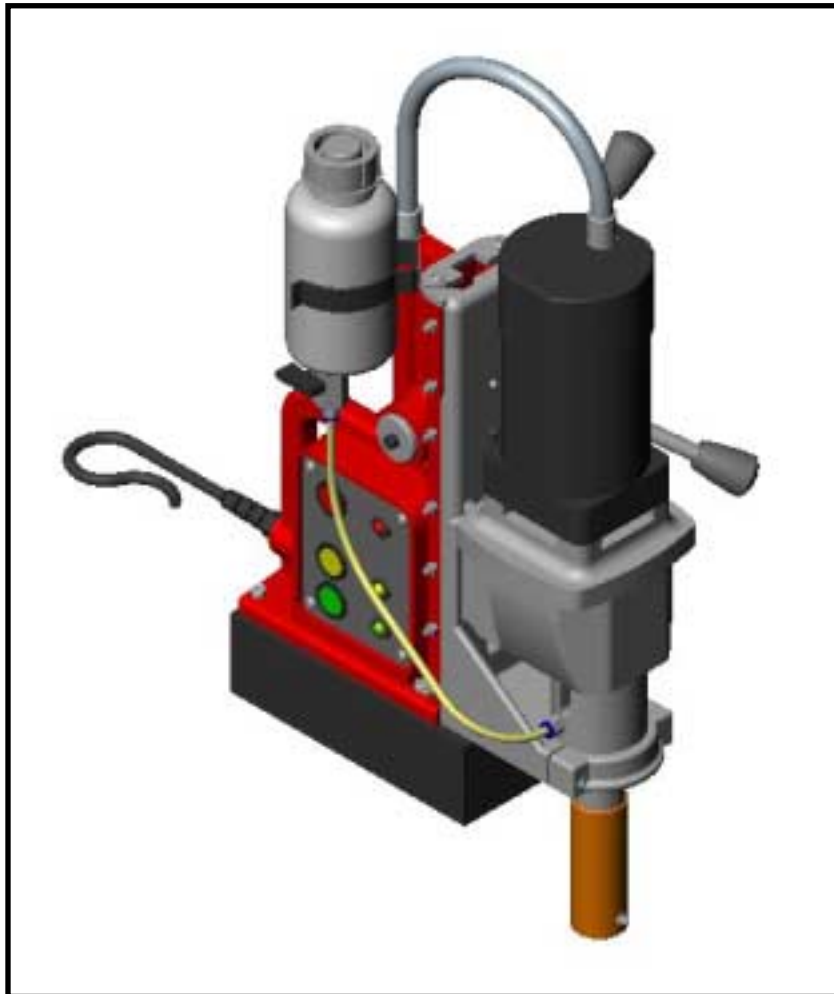

**Operators Instruction Manual
And Spare Parts Listings**

Index

- Chapter 1. Technical Overview.
- Chapter 2. Warnings and Safety Instructions.
- Chapter 3. Operating Instructions.
- Chapter 4. Maintenance Instructions.
- Chapter 5. Exploded views and parts lists.
Motor break down and parts list.
Panel wiring diagram.

Introduction

Congratulations on the purchase of your new, lightweight multi-purpose magnetic base drill. This is a high quality product with unique features that make it the perfect solution for your entire hole drilling requirements.

- Easy to use and rugged design makes the E100/32 a cost effective solution to drilling clean, accurately positioned holes in your work piece.
- Powered by an EIBENSTOCK UNI-III motor.

Chapter 1. Technical Overview.

Machine	E100/32
Clamping force (Kg)	1800
Speed (RPM)	50-130/160-540
Size (LxWxH) (mm)	320x135x510
Cutter Capacity (mm)	12 - 85
Twist Drill Capacity (mm)	32
Power Consumption (Watts)	1800
Weight (Kg)	26

Chapter 2. Warnings and Safety Instructions.

Read these instructions carefully before operating, maintaining or servicing this tool.
Please keep these instructions in a safe accessible place.



Read to fully understand and observe the following safety precautions and warnings. Careless or improper use of this equipment may result in serious or fatal injury.



Always wear eye, head and ear protection equipment, when using this tool



WARNING!
Indicates instant possibility of severe personal injury or loss of life, if instructions are not followed.



CAUTION!
Indications a possibility of personal injury or equipment damage, if instructions are not followed.

Operator Safety

- Always read the instructions carefully so as to avoid any injury or damage when unfamiliar with this equipment.
- Always wear a safety face shield or goggles.
- Wear ear defenders when using this equipment.
- Always wear heavy clothing, boots and gloves. Do not wear loose clothing, short pants, sandals etc. and ensure that long hair is tied up above shoulder length.
- Do not operate this equipment when tired, ill or under the influence of alcohol, drugs or medication.
- Never allow an inexperienced person operate this equipment.
- Never operate the equipment in damp, or water logged area.
- Keep all carrying handles and levers free from oil.

Tool Safety

- Inspect the entire piece of equipment before use.
- Replace damaged components, lubricate where necessary and ensure that all fasteners are secure.
- Always use a safety chain to secure the equipment when it is being used above the ground.
- Use only accessories that have been recommended by the manufacturer. Failure to do so could result in damage to the tool and may invalidate the warranty.



WARNING!

Never modify the tooling any way. Do not use your equipment for any job other than for which it is intended.

- Keep hands away from the cutter when it is rotating. Ensure that it has stopped rotating and is disconnected from the power source before touching the cutter.
- Do not attempt to gain access into the electrical panel. There is risk of electrical shock.
- Never use a larger diameter cutter than specified for use with this equipment.
- Do not attempt to connect the equipment to a power source other than that specified by the manufacturer.
- Ensure that the cutter being used is sharp and free from damage.

Maintenance safety

- Maintain according to the manufacturers recommended procedures.
- Disconnect the equipment from the power source before attempting any maintenance.
- Use only genuine replacement components as recommended by the manufacturer.

Transport and Storage

- Before moving the tool, ensure that the cutter has stopped rotating.
- Carry the tool with the cutter pointing away from the body to avoid laceration.
- After use, clean the equipment and its accessories and store in a dry place.
- Store the equipment along with the maintenance tools in its correct carrying case when not in use.

Chapter 3. Operating Instructions.



Ensure that the unit is disconnected from the power before working on the machine.

- **Insert Pilot Pin.**

The pilot pin is used to align the cutter and eject the slug on completion of the cut.

Slide the pilot through the hole in the centre of the cutter shank.



- **Fit the Cutter.**

Two grub screws are used to secure the cutter to the arbor. The cutter shank has two flats that must be aligned with the grub screws in the arbor.

Insert the cutter shank into the arbor. The screws must be tightened evenly so that the cutter is prevented from moving. The screws are tightened using the **5mm** Allen key supplied.

(A cutter with a shank diameter of 19.05mm/ $\frac{3}{4}$ " and cutting diameter of no larger than 85mm must be used).



- **Mark the centre of the required hole.**

- **Position the Machine.**

Ensure that the workpiece is clean and flat. Position the machine by aligning the pilot with the holes centre mark.

- **Fit the safety strap/chain.**

- **Connect the machine to the power source.**

Switch on the power by depressing the RED power switch on the side panel.



- **Energize the magnet.**

Switch on the magnetic base by depressing the YELLOW magnet switch.

CHECK that the pilot is still aligned with the hole centre mark, as energizing the magnetic base can cause the machine to move.



- **Apply Coolant**

Using cutting oil can increase the tool life and ensures that the slug is ejected cleanly. Fill or part fill the side mounted oil reservoir and turn on the tap at the bottom of the bottle. Fluid should now flow through the arbor and on to the cutter.

Check for fluid flow before you begin cutting and adjust the flow using the tap.

- **Start Cutting**

ALWAYS ENSURE THAT CUTTING GUARDS ARE IN PLACE.

Start the drill by depressing the GREEN drill switch.

Lower the cutter to the surface by turning the handle; and

with light pressure cut an initial groove. Increase pressure until motor is loaded and maintain steady pressure until cut is complete.



VISO10 drill guard

- **Finish Cutting**

When the cut is complete the slug will be ejected from the cutter. Raise the cutter again; stop the motor and switch of the magnet.

- **Changing the Arbor**

To remove the arbor, insert drift into slot on drill head casing and tap lightly with a mallet.

NOTE: –

- Applying too much pressure will not speed the cut, it will reduce the life of the tool and may cause damage to the motor.
- If swarf becomes blue in colour then more cutting oil is required.
- If the power is interrupted during the cut, the magnet must be reset before the motor will restart.

Chapter 4. Maintenance Instructions

- Occasionally apply a few drops of oil to the rack gear teeth.
- The bearings of the feed shaft are self-lubricating and must not be greased.
- Grease the sliding surface of the carriage with MOLYCOTE grease.
- When not in use or being transported the unit should be kept in the case supplied.
- After use ensure unit is clean of swarf and dirt.
- Parts that are worn or damaged should be replaced immediately with original UNIBOR replacements.
- Ensure all cutting edges are sharp when in operation. Using blunt cutting tools may lead to an overload of the motor.
- After repeated use, the cradle may become loose. This is remedied by adjusting the tension screws on the side of the body. Put 2.5mm Allen Key into head of cradle retaining nuts, using 8mm Spanner undo the locking nuts anti-clockwise holding the Allen key without moving grub screws. Using the Allen Key gently tighten screws in series until the cradle moves freely in the slide but does not allow the motor to wobble. When adjustment is complete re-tighten locking nuts clockwise.



Chapter 5. Exploded Views

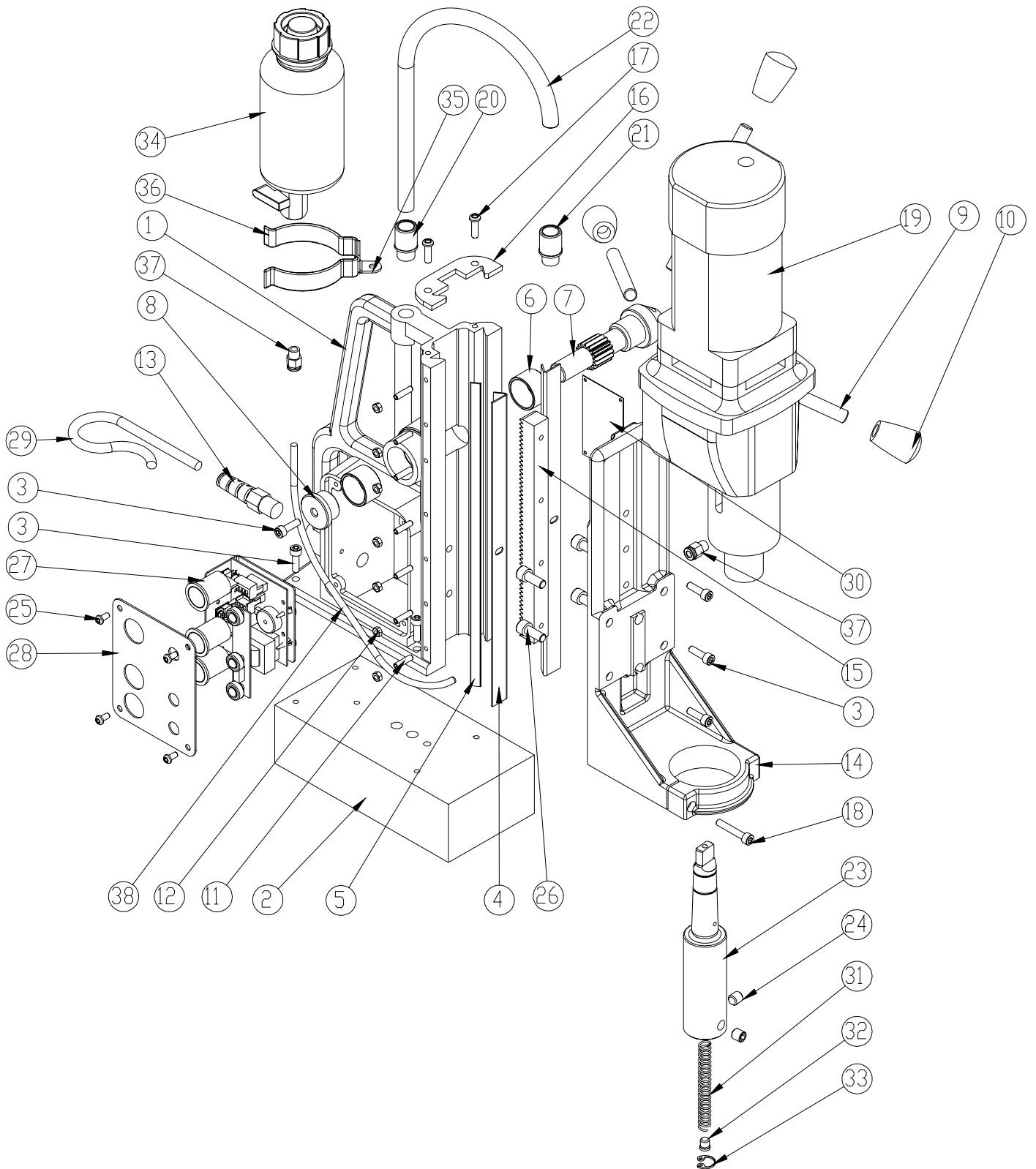

Chapter 5. Component listing.

ITEM NO.	QTY.	PART NO.	DESCRIPTION
1	1	10061	BODY - RED
2	1	M0033	MAGNET BASE
3	8	SC620CAP	M6 X 20 CAP SCREW
4	2	60101A	BRASS STRIP
5	1	20387	G.F.S.
6	2	M0081	BUSHING
7	1	M0042	PINION
8	1	M0072	PINION END CAP
9	3	10081	HANDLE 12MM
10	3	10082	HANDLE KNOB
11	7	SC5GRUB	M5 X 20 LONG GRUB SCREW
12	7	NUT-M5	M5 NYLOC NUT
13	1	10231	STRAIN RELIEF
14	1	20355	EIBENSTOCK CRADLE
15	1	10075	RACK
16	1	10084	TOP PLATE
17	2	SC620BUT	M6 X 20 BUTTON HEAD SCREW
18	1	SC635CAP	M6 X 35 CAP SCREW
19	1	EIB03	EIBENSTOCK UNI 3 DRILL - 110V
20	1	40026	M16 PUSH FIT GLAND
21	1	40025	PG9 PUSH FIT GLAND
22	1	M0443	CONDUIT - MAGTAP M13
23	1	A33075 A34075	ARBOR - No. 3 MT - 2" LONG ARBOR - No. 3 MT - 3" LONG
24	2	SC1010GRUB	M10 X 10 GRUB SCREW
25	4	SC510BUT	M5 X 10 BUTTON SCREW
26	4	SC820CAP	M8 X 20 CAP SCREW
27	1	PANELP	PANEL ASSEMBLY - NO FACIA
28	1	20305N	SWITCH PLATE
29	1	CABL03	POWER CABLE - 14 GAUGE
30	1	10101	WARNING PLATE
31	1	spr101	ARBOR SPRING
32	1	10205a	ARBOR EJECTION PLUG
33	1	CCP-19	19MM INTERNAL CIRCLIP
34	1	OIL05	OIL CUP ASSEMBLY
35	1	10060	OIL CUP CLIP MOUNTING PLATE
36	1	10076	OIL CUP CLIP
37	2	50015B	PUSH FITTING
38	1	OIL PIPE	OIL TUBE

Additional Parts (Not Shown)

ITEM NO.	QTY.	PART NO.	DESCRIPTION
-	1	511204	DRIFT (No. 3 MORSE TAPER)
-	1	STRAP01	POLYESTER WEBBING SAFETY STRAP
-	1	KEY01	ALLEN KEY 2.5MM
-	1	KEY03	ALLEN KEY 4MM
-	1	KEY04	ALLEN KEY 5MM
-	1	CASE14	CARRYING CASE - UNIBOR - PLASTIC
-	1	BOX01	BOX (UNIBOR SLEEVE)
-	1	VISO10	SAFETY GUARD UNI 3
-	2	10093	M6 X 35 GUARD THUMB SCREW
-	2	10094	M6 GUARD SPACER
-	2	10089	LARGE 2 LEG GUARD GUIDE

PANEL COMPONENT LIST

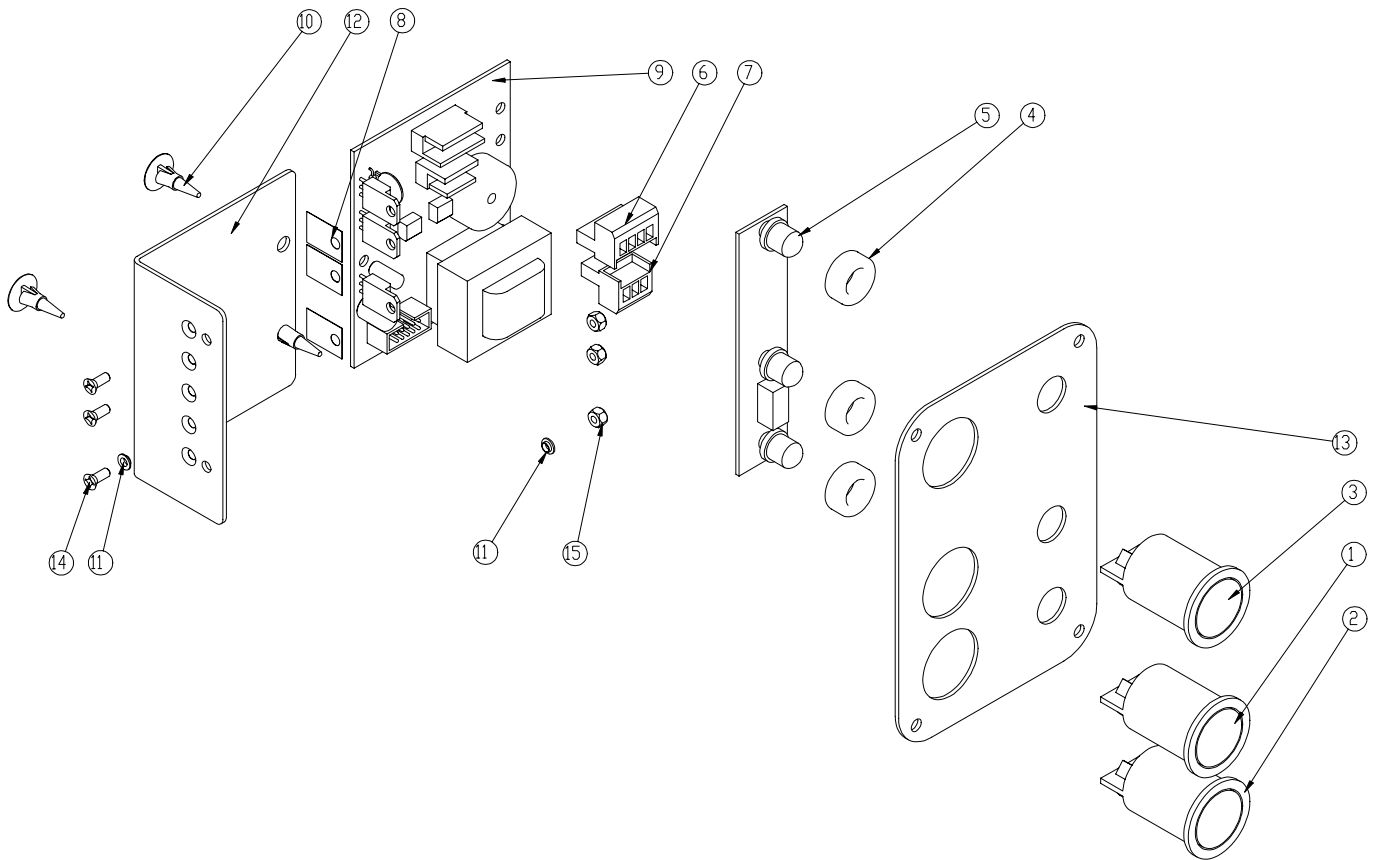

Item No.	Stock Code	Description	Quantity
1	MM1-1	MM1 MAGNET BUTTON - YELLOW	1
2	MM1-2	MM1 MOTOR BUTTON - GREEN	1
3	MM1-10	MM POWER BUTTON - RED	1
4	MM1-3	MM1 L.E.D. GROMMET	3
5	MM1-4	MM1 LED BOARD – C/W LEDs	1
6		NO LONGER REQUIRED	
7		NO LONGER REQUIRED	
8		NO LONGER REQUIRED	
9	IMI-MM1-5	REPLACEMENT PCB BOARD	1
10	MM1-16	STAND OFF CLIP FOR NEW PANEL	2
11		NO LONGER REQUIRED	
12	MM1-17	PCB SUPPORT PLATE	1
13	M0241B	SWITCH PLATE	1
14	SC316CSK-X	M3 x 16 PHILIPS HEAD SCREW	3
15	NUT-M3	M3 LOCK NUT	3

Chapter 5. Electric Motor Break Down

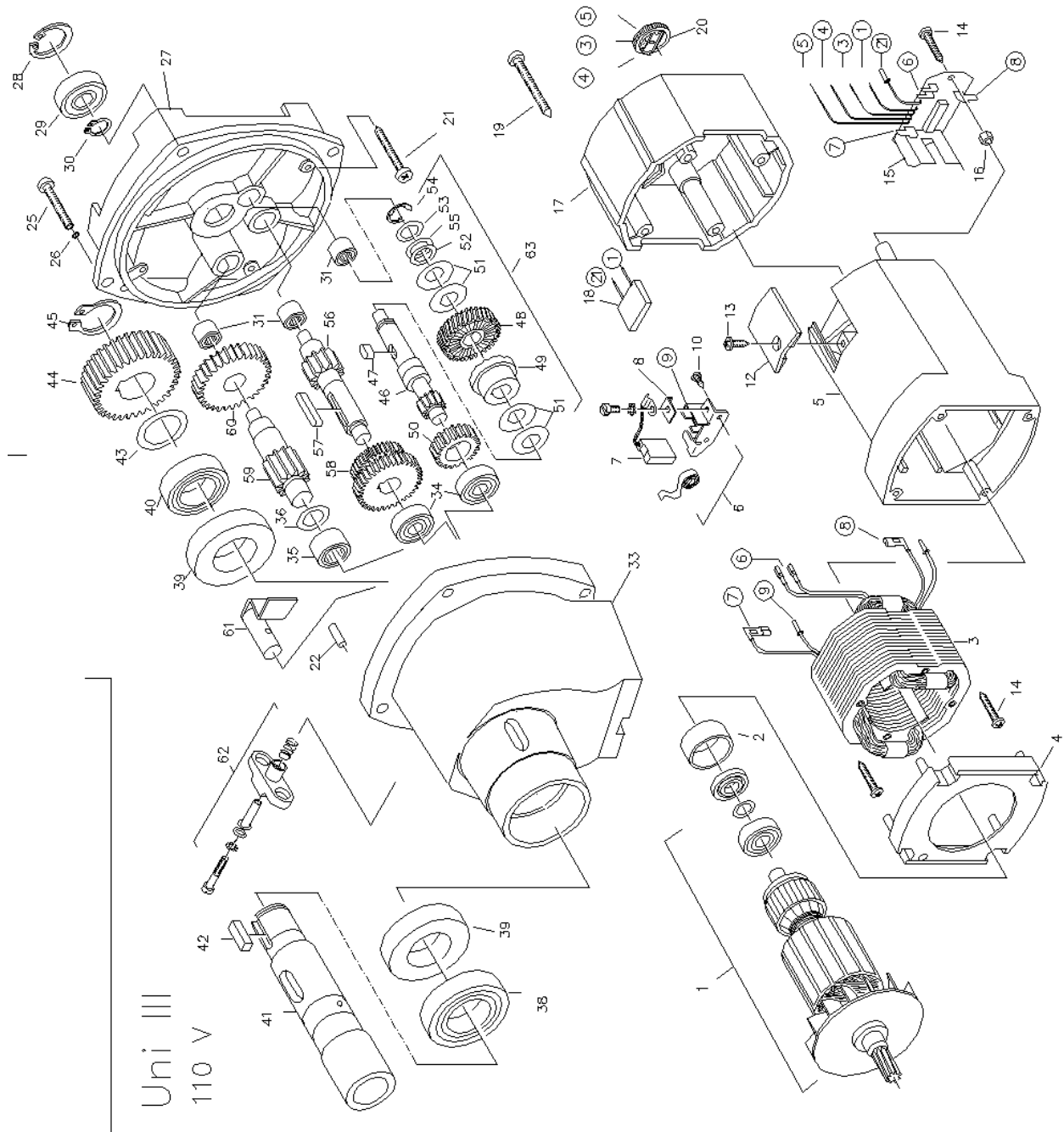

Item No.	Part No.	Description
1	610001	ARMATURE ASSEMBLY
2	610002	BEARING HOUSING
3	610003	FIELD COIL
4	610004	FAN COVER
5	610005	MOTOR HOUSING
6	610006	BRUSH HOLDER ASSEMBLY
7	610007	CARBON BRUSH
8	610008	BRUSH CONNECTION
10	610010	SCREW (2.9X9.5)
12	610012	BRUSH COVER
13	610013	SCREW HC (4.2X13)
14	610014	SCREW HC (4.2X25)
15	610015	CIRCUIT BOARD
16	610016	M5 NUT
17	610017	DRILL CAP
18	610018	SUPPRESSOR 0.1/250V
19	610019	SCREW HC (4.8X50)
20	610020	SPEED CONTROL KNOB
21	610021	SCREW (4.8X45)
22	610022	DOWEL (5X12)
25	610025	MACHINE SCREW
26	610026	SPRING WASHER A6
27	610027	GEAR HOUSING BACK PLATE
28	610028	CIRCLIP 32/1.2
29	610029	BEARING 6201.2Z
30	610030	CIRCLIP 11/1
31	610031	NEEDLE BEARING
33	610033	GEAR HOUSING
34	610034	BEARING 6000
35	610035	NEEDLE BEARING RNA4900
36	610036	WASHER 4900
38	610038	BEARING 6006 2RS
39	610039	SEAL 30x47x7
40	610040	BEARING 6005 2RS
41	610041	SPINDLE
42	610042	KEY B6x6x20
43	610043	COMPRESSOR RING 35/25X0.1
44	610044	DRIVE GEAR 24/1.2
45	610045	CIRCLIP 24/1/2
46	610046	TRAILER GEAR 1
47	610047	KEY
48	610048	CLUTCH GEAR
49	610049	CLUTCH COUPLING
50	610050	GEAR
51	610051	BELVAR WASHERS 28/12.2X1
52	610052	COMPRESSION RING 12/18X0.5
53	610053	SPACER
54	610054	CIRCLIP 9
55	610055	SPACER
56	610056	TRAILER GEAR 2
57	610057	KEY A5 X 5 X 28
58	610058	DOUBLE GEAR
59	610059	TRAILER GEAR
60	610060	GEAR 2
61	610061	GEAR CHANGE LEVER
62	610062	GEAR CHANGE ASSEMBLY
63	610063	ASSEMBLY PARTS (PARTS 46-55)

