

Magnetic Base Drilling Machine

E40

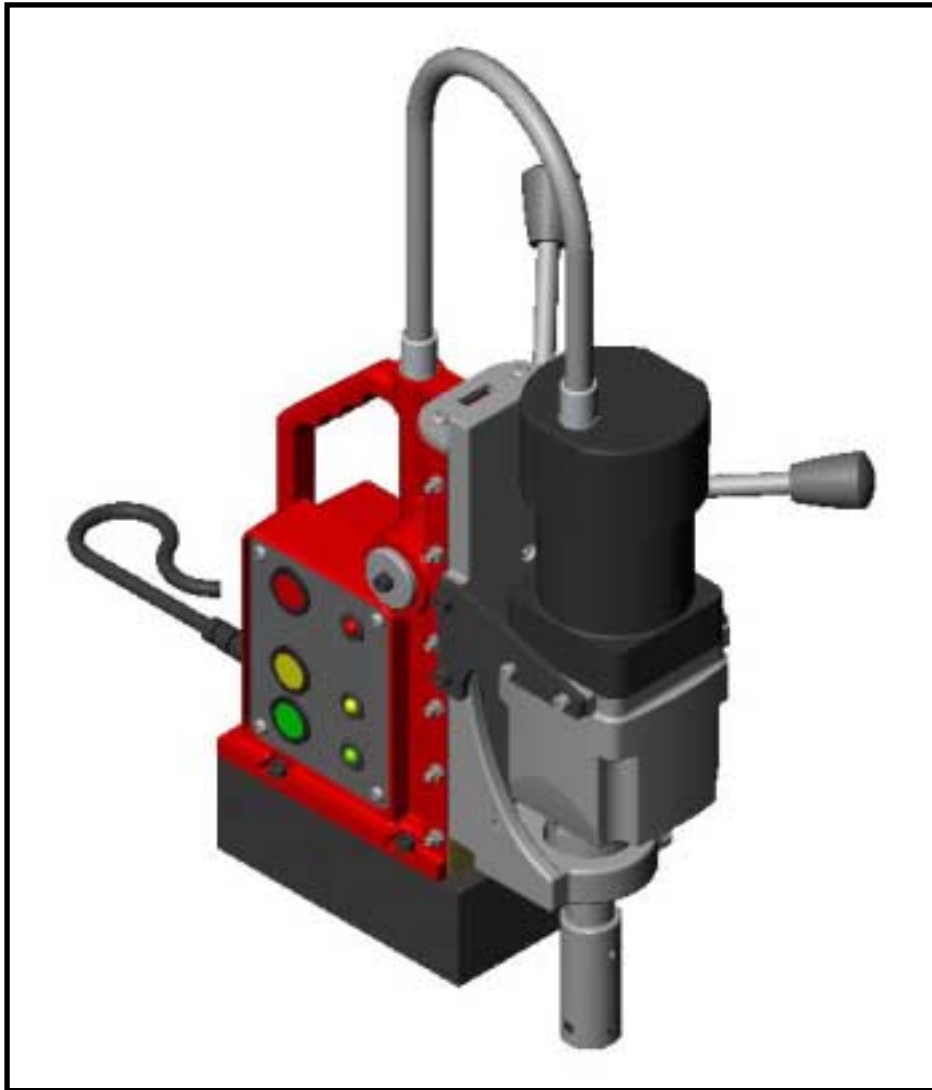

**Operators Instruction Manual
And Spare Parts Listings**

Index

- Chapter 1. Technical Overview.
- Chapter 2. Warnings and Safety Instructions.
- Chapter 3. Operating Instructions.
- Chapter 4. Maintenance Instructions.
- Chapter 5. Exploded views and parts lists.
Motor break down and parts list.
Panel wiring diagram.

Introduction

Congratulations on the purchase of your new, lightweight multi-purpose magnetic base drill. This is a high quality product with unique features that make it the perfect solution for your entire hole drilling requirements.

- Easy to use and rugged design makes the E40 a cost effective solution to drilling clean, accurately positioned holes in your work piece.
- Powered by an EIBENSTOCK UNI-II motor.

Chapter 1. Technical Overview.

Machine	E40
Clamping force (Kg)	910
Speed (RPM)	430/770
Size (LxWxH) (mm)	285x100x412
Cutter Capacity (mm)	12 - 40
Twist Drill Capacity (mm)	19
Power Consumption (Watts)	1600
Weight (Kg)	15

Chapter 2. Warnings and Safety Instructions.

Read these instructions carefully before operating, maintaining or servicing this tool. Please keep these instructions in a safe accessible place.



Read to fully understand and observe the following safety precautions and warnings. Careless or improper use of this equipment may result in serious or fatal injury.



Always wear eye, head and ear protection equipment, when using this tool



WARNING!

Indicates instant possibility of severe personal injury or loss of life, if instructions are not followed.



CAUTION!

Indications a possibility of personal injury or equipment damage, if instructions are not followed.

Operator Safety

- Always read the instructions carefully so as to avoid any injury or damage when unfamiliar with this equipment.
- Always wear a safety face shield or goggles.
- Wear ear defenders when using this equipment.
- Always wear heavy clothing, boots and gloves. Do not wear loose clothing, short pants, sandals etc. and ensure that long hair is tied up above shoulder length.
- Do not operate this equipment when tired, ill or under the influence of alcohol, drugs or medication.
- Never allow an inexperienced person operate this equipment.
- Never operate the equipment in damp, or water logged area.
- Keep all carrying handles and levers free from oil.

- Keep hands away from the cutter when it is rotating. Ensure that it has stopped rotating and is disconnected from the power source

Tool Safety

- Inspect the entire piece of equipment before use.
- Replace damaged components, lubricate where necessary and ensure that all fasteners are secure.
- Always use a safety chain to secure the equipment when it is being used above the ground.
- Use only accessories that have been recommended by the manufacturer. Failure to do so could result in damage to the tool and may invalidate the warranty.



WARNING!

Never modify the tooling any way. Do not use your equipment for any job other than for which it is intended.

Maintenance safety

- Maintain according to the manufacturers recommended procedures.

before touching the cutter.

- Do not attempt to gain access into the electrical panel. There is risk of electrical shock.
 - Never use a larger diameter cutter than specified for use with this equipment.
 - Do not attempt to connect the equipment to a power source other than that specified by the manufacturer.
 - Ensure that the cutter being used is sharp and free from damage.
- Disconnect the equipment from the power source before attempting any maintenance.
 - Use only genuine replacement components as recommended by the manufacturer.

Transport and Storage

- Before moving the tool, ensure that the cutter has stopped rotating.
- Carry the tool with the cutter pointing away from the body to avoid laceration.
- After use, clean the equipment and its accessories and store in a dry place.
- Store the equipment along with the maintenance tools in its correct carrying case when not in use.

Chapter 3. Operating Instructions.



Ensure that the unit is disconnected from the power before working on the machine.

- **Insert Pilot Pin.**

The pilot pin is used to align the cutter and eject the slug on completion of the cut. Slide the pilot through the hole in the centre of the cutter shank.



- **Fit the Cutter.**

Two grub screws are used to secure the cutter to the arbor. The cutter shank has two flats that must be aligned with the grub screws in the arbor.

Insert the cutter shank into the arbor. The screws must be tightened evenly so that the cutter is prevented from moving. The screws are tightened using the **5mm** Allen key supplied.

(A cutter with a shank diameter of 19.05mm/3/4" and cutting diameter of no larger than 40mm must be used).



- **Mark the centre of the required hole.**

- **Position the Machine.**

Ensure that the workpiece is clean and flat. Position the machine by aligning the pilot with the holes centre mark.

- **Fit the safety strap/chain.**

- **Connect the machine to the power source.**

Switch on the power by depressing the RED power switch on the side panel.



- **Energize the magnet.**

Switch on the magnetic base by depressing the **YELLOW** magnet switch.
CHECK that the pilot is still aligned with the hole centre mark, as energizing the magnetic base can cause the machine to move.



- **Apply Coolant**

Using cutting oil can increase the tool life and ensures that the slug is ejected cleanly.
Apply a generous amount of cutting oil to the surface to be cut.
If cutting surface is vertical or steeply inclined, then cutting paste, gel or foam should be used.

- **Start Cutting**

ALWAYS ENSURE THAT CUTTING GUARDS ARE IN PLACE.

Start the drill by depressing the **GREEN** drill switch.
Lower the cutter to the surface by turning the handle; and with light pressure cut an initial groove. Increase pressure until motor is loaded and maintain steady pressure until cut is complete.



VISO09 drill guard

- **Finish Cutting**

When the cut is complete the slug will be ejected from the cutter. Raise the cutter again; stop the motor and switch of the magnet.

- **Changing the Arbor**

To remove the arbor, insert drift into slot on drill head casing and tap lightly with a mallet.

NOTE: –

- Applying too much pressure will not speed the cut, it will reduce the life of the tool and may cause damage to the motor.
- If swarf becomes blue in colour then more cutting oil is required.
- If the power is interrupted during the cut, the magnet must be reset before the motor will restart.

Chapter 4. Maintenance Instructions

- Occasionally apply a few drops of oil to the rack gear teeth.
- The bearings of the feed shaft are self-lubricating and must not be greased
- Grease the sliding surface of the carriage with MOLYCOTE grease.
- When not in use or being transported the unit should be kept in the case supplied.
- After use ensure unit is clean of swarf and dirt.
- Parts that are worn or damaged should be replaced immediately with original UNIBOR replacements.
- Ensure all cutting edges are sharp when in operation. Using blunt cutting tools may lead to an overload of the motor.
- After repeated use, the cradle may become loose. This is remedied by adjusting the tension screws on the side of the body. Put 2.5mm Allen Key into head of cradle retaining nuts, using 8mm Spanner undo the locking nuts anti-clockwise holding the Allen key without moving grub screws. Using the Allen Key gently tighten screws in series until the cradle moves freely in the slide but does not allow the motor to wobble. When adjustment is complete re-tighten locking nuts clockwise.



Chapter 5. Exploded Views

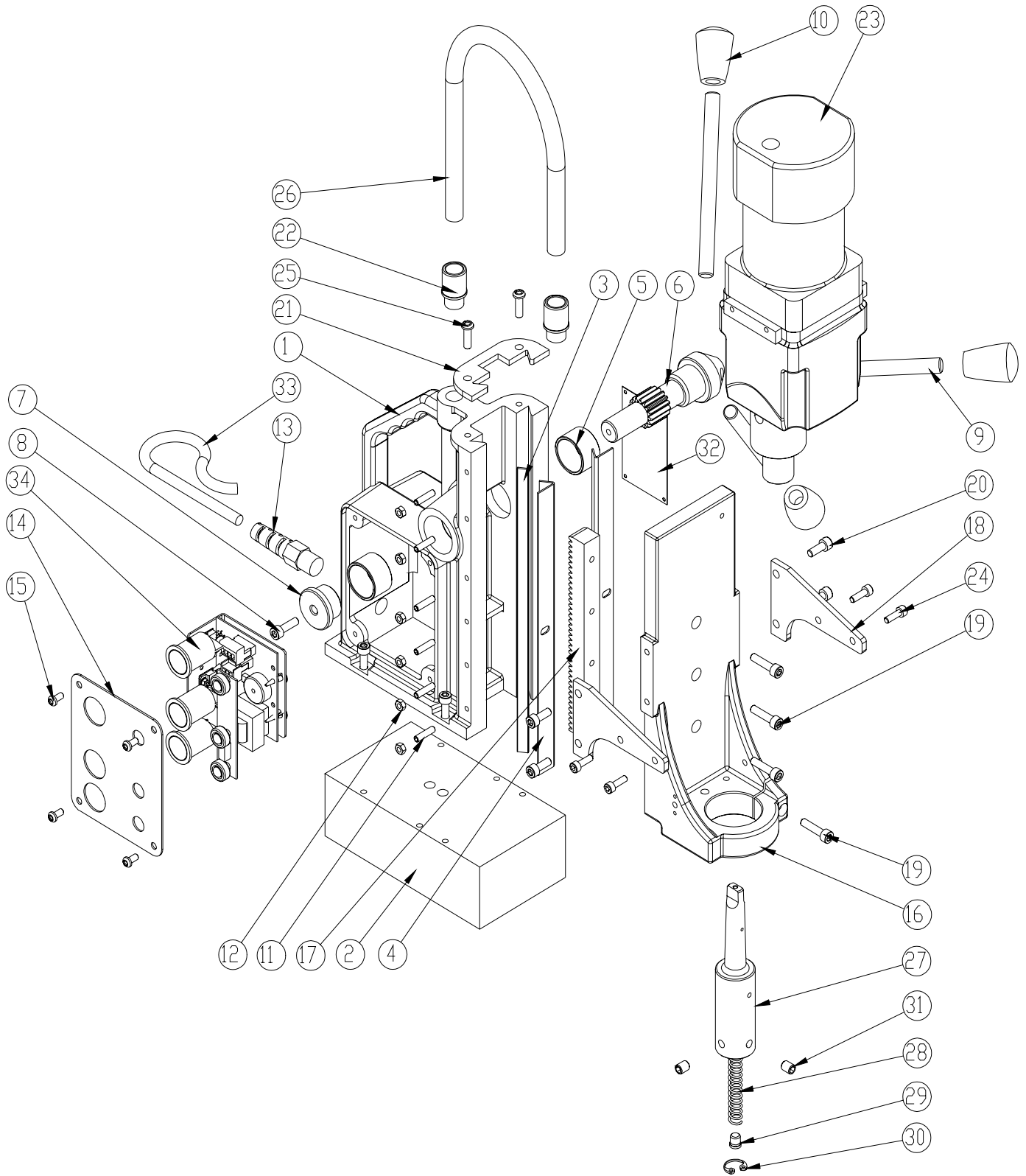

Chapter 5. Component listing.

ITEM NO.	QTY.	PART NO.	DESCRIPTION
1	1	20348	BODY - RED
2	1	M0034	MAGNET BASE
3	1	20389	G.F.S.
4	2	60100A	BRASS STRIP ANGLED
5	2	M0081	BUSHING - PINION
6	1	M0042	PINION
7	1	M0072	PINION END CAP
8	5	SC620CAP	M6 X 20 CAP SCREW
9	3	10081	HANDLE
10	3	10082	HANDLE KNOB
11	6	SC5GRUB	M5 X 20 LONG GRUB SCREW
12	6	NUT-M5	M5 NYLOC NUT
13	1	10231	STRAIN RELIEF
14	1	20305N	SWITCH PLATE
15	4	SC510BUT	M5 X 10 BUTTON SCREW
16	1	20145	CRADLE
17	1	10215	RACK
18	2	10362	SIDE BRACKET
19	4	SC625CAP	M6 X 25 CAP SCREW
20	4	SC616CAP	M6 X 16 CAP SCREW
21	1	10084	TOP PLATE - UNIBOR
22	2	40026	M16 PUSH FIT GLAND
23	1	EIB02	EIBENSTOCK UNI 2 DRILL - 110V
24	4	SC516CAP	M5 X 16 CAP SCREW
25	2	SC620BUT	M6 X 20 BUTTON HEAD SCREW
26	1	M0444	CONDUIT - BLACK
27	1	A20075	ARBOR - No. 2 MORSE TAPER
28	1	SPR101	ARBOR SPRING
29	1	10205A	ARBOR EJECTION PLUG
30	1	CCP-19	19MM INTERNAL CIRCLIP
31	2	SC810GRUB	M8 X 10 GRUB SCREW
32	1	10101	WARNING PLATE
33	1	CABL02	POWER CABLE - 16 GAUGE
34	1	PANELP	PANEL ASSEMBLY - NO FACIA

Additional Parts (Not Shown)

ITEM NO.	QTY.	PART NO.	DESCRIPTION
-	1	411204	DRIFT - No. 2 MORSE TAPER
-	1	STRAP01	POLYESTER WEBBING SAFETY STRAP
-	1	KEY01	ALLEN KEY 2.5MM
-	1	KEY03	ALLEN KEY 4MM
-	1	KEY04	ALLEN KEY 5MM
-	1	CASE01	CARRYING CASE - MINIBOR - PLASTIC
-	1	BOX05	BOX (MINIBOR SLEEVE)
-	1	VISO09	GUARD TO SUIT UNI 2 MOTOR
-	2	10099	M6 X 16 GUARD THUMB SCREW
-	2	10094	M6 GUARD SPACER
-	2	10095	SMALL 2 LEG GUARD GUIDE

PANEL COMPONENT LIST

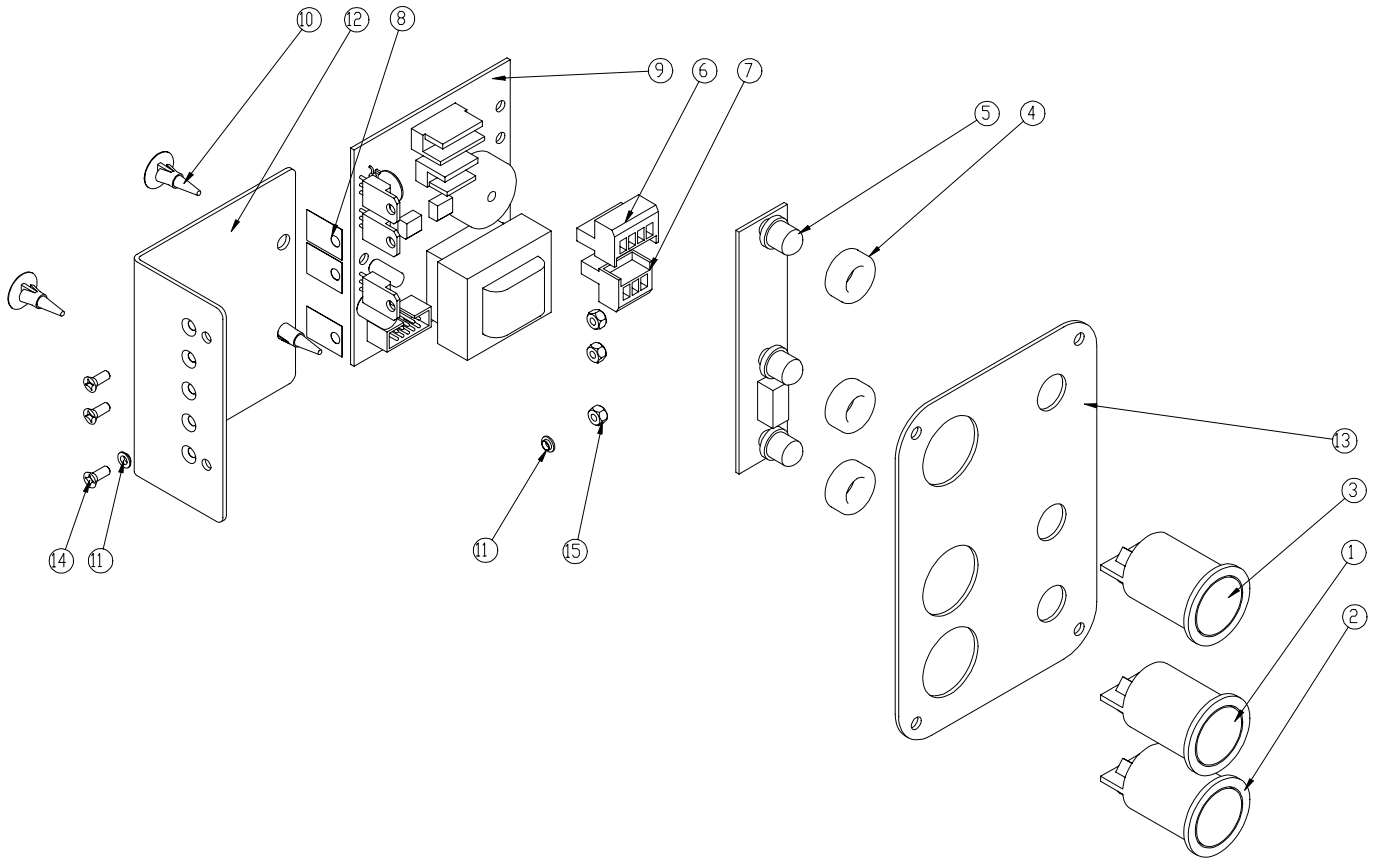

Item No.	Stock Code	Description	Quantity
1	MM1-1	MM1 MAGNET BUTTON - YELLOW	1
2	MM1-2	MM1 MOTOR BUTTON - GREEN	1
3	MM1-10	MM POWER BUTTON - RED	1
4	MM1-3	MM1 L.E.D. GROMMET	3
5	MM1-4	MM1 LED BOARD – C/W LEDs	1
6		NO LONGER REQUIRED	
7		NO LONGER REQUIRED	
8		NO LONGER REQUIRED	
9	IMI-MM1-5	REPLACEMENT PCB BOARD	1
10	MM1-16	STAND OFF CLIP FOR NEW PANEL	2
11		NO LONGER REQUIRED	
12	MM1-17	PCB SUPPORT PLATE	1
13	M0241B	SWITCH PLATE	1
14	SC316CSK-X	M3 x 16 PHILIPS HEAD SCREW	3
15	NUT-M3	M3 LOCK NUT	3

Chapter 5. Electric Motor Break Down

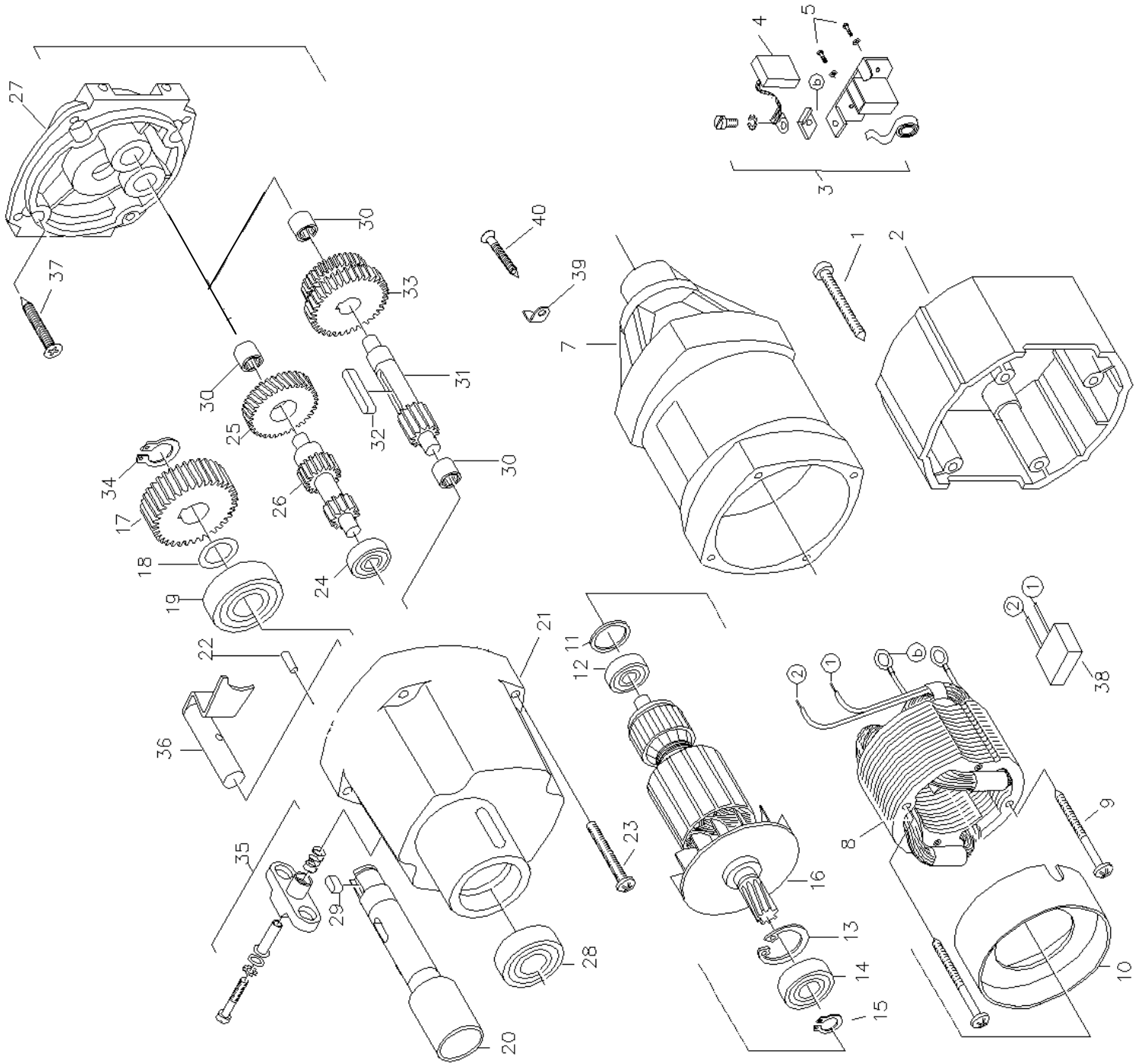

Item No.	Part No.	Description
1	410001	SCREW - SELF TAPPING
2	410002	MOTOR CAP
3	410003	BRUSH HOLDER
4	410004	BRUSH (PAIR)
5	410005	SCREW
6	410006	SPRING WASHER
7	410007	MOTOR CASING
8	410008	STATOR (COMPLETE)
9	410009	SCREW - SELF TAPPING
10	410010	FAN COVER
11	410011	O-RING
12	410012	GROOVED BALL BEARING
13	410013	LOCKING RING
14	410014	GROOVED BALL BEARING
15	410015	LOCKING RING
16	410016	ROTOR
17	410017	SPINDLE WHEEL
18	410018	FITTING WASHER
19	410019	GROOVED BALL BEARING
20	410020	WORK SPINDLE
21	410021	GEARBOX HOUSING
22	410022	NOTCHED PIN
23	410023	SCREW - SELF TAPPING
24	410024	GROOVED BALL BEARING
25	410025	INTERMEDIATE WHEEL
26	410026	DOUBLE GEAR
27	410027	GEAR CASE COVER
28	410028	GROOVED BALL BEARING
29	410029	KEY A5 X 5 X 12
30	410030	NEEDLE BEARING
31	410031	SHAFT WITH CLUSTER GEARS
32	410032	KEY A5 X 5 X 28
33	410033	CLUSTER GEARS
34	410034	LOCKING RING
35	410035	GEAR SWITCH COMPLETE
36	410036	COUPLING BOLT COMPLETE
38	410038	CONDENSOR
39	410039	PLASTIC CLIP
40	410040	SCREW - SELF TAPPING
*41	610015	VARIABLE SPEED CIRCUIT BOARD
*42	610020	SPEED CONTROL KNOB
43	410043	GREASE CUP
44	410044	GASKET

*If equipped.

Wiring Diagrams

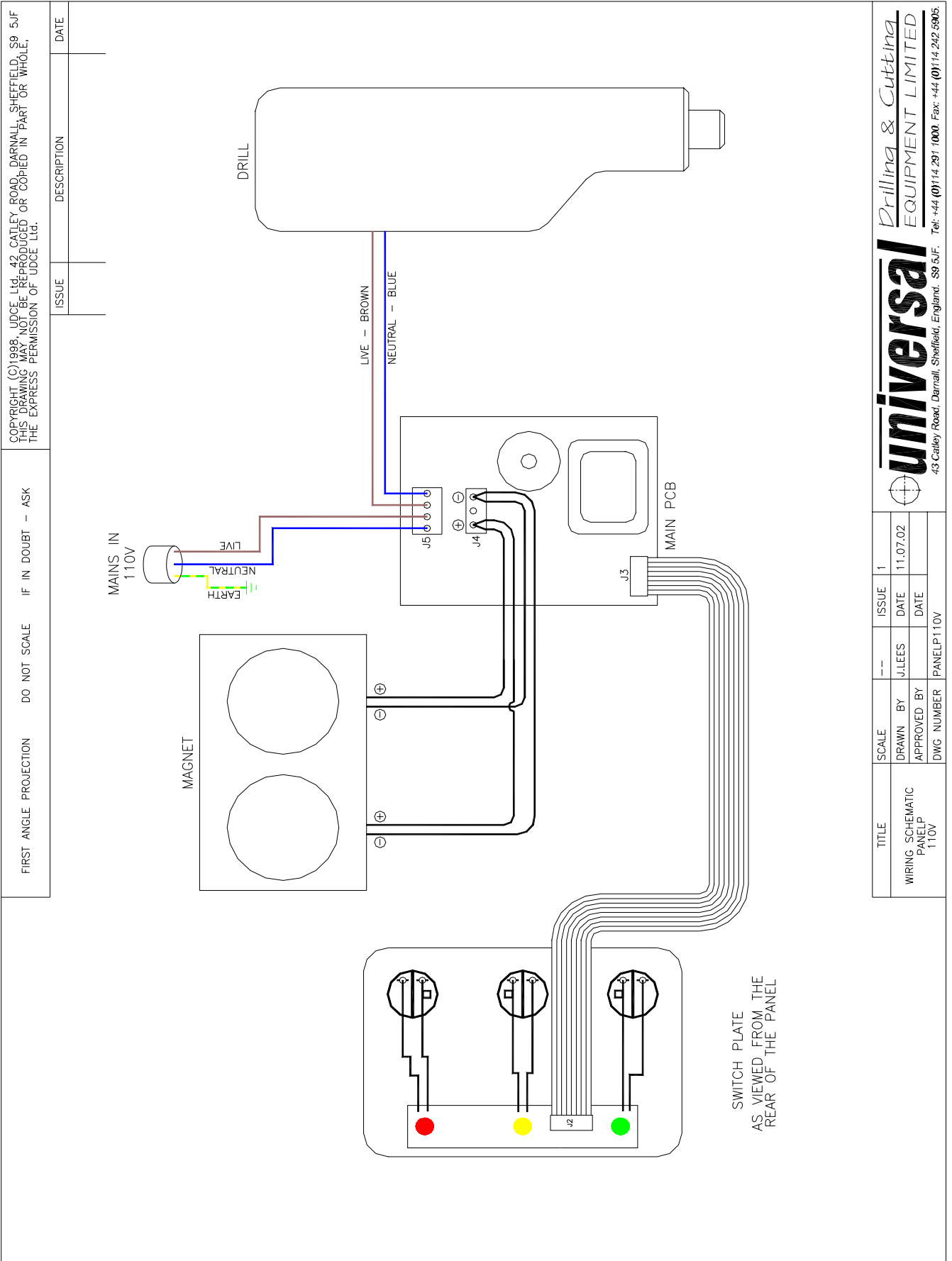

TITLE	SCALE	ISSUE	DATE
WIRING SCHEMATIC PANELP 110V	--	1	11.07.02
		J.LEES	DATE
DWG NUMBER		PANELP110V	DATE

universal
Drilling & Cutting
EQUIPMENT LIMITED

43 Catley Road, Darnall, Sheffield, England. S9 5JF. Tel: +44 (0)114 291 1000. Fax: +44 (0)114 242 5905.