

# Magnetic Base Drilling Machine

## **S6032-5**

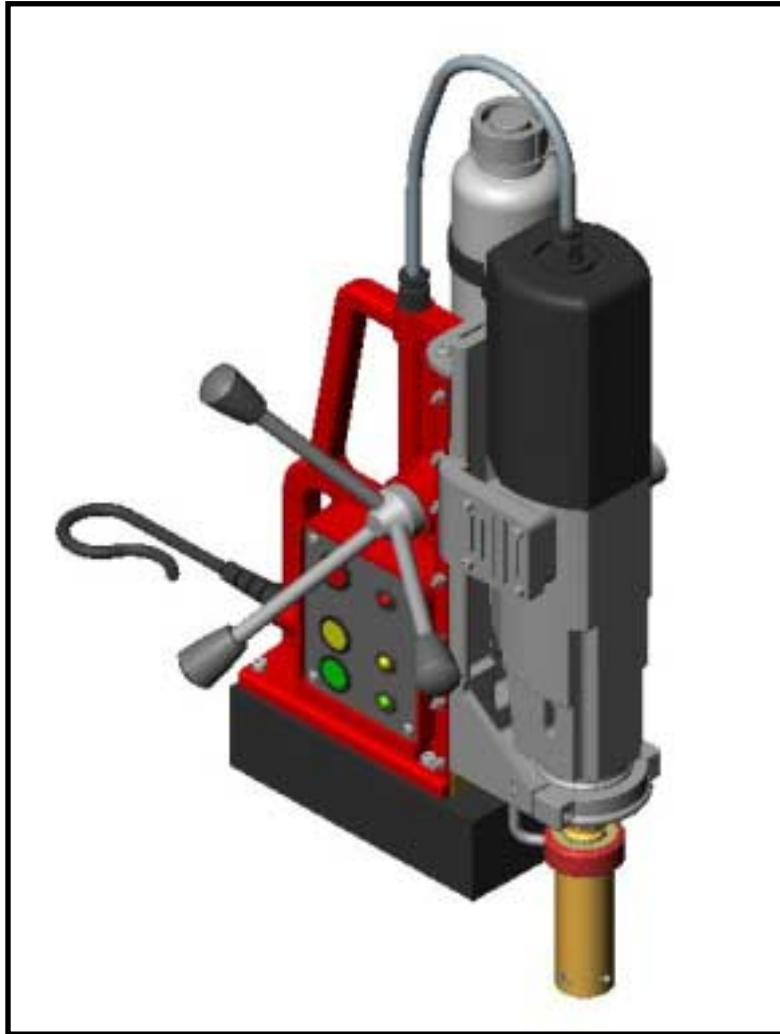

**Operators Instruction Manual  
And Spare Parts Listings**

# Index

- Chapter 1. Technical Overview.
- Chapter 2. Warnings and Safety Instructions.
- Chapter 3. Operating Instructions.
- Chapter 4. Maintenance Instructions.
- Chapter 5. Exploded views and Spares lists.  
Drill break down and Parts list  
Electric motor break down

## Introduction

Congratulations on the purchase of your new, lightweight multi-purpose magnetic base drill. This is a high quality product with unique features that make it the perfect solution for your entire hole drilling requirements.

- Easy to use and rugged design makes the S6032-5 a cost effective solution to drilling clean, accurately positioned holes in your work piece.
- Powered by CASALS motor.

## Chapter 1. Technical Overview.

Machine	S6032-5
Clamping force (Kg)	1410
Speed (RPM)	70-275/140-540
Size (LxWxH) (mm)	300x100x520
Cutter Capacity (mm)	12 - 100
Twist Drill Capacity (mm)	32
Power Consumption (Watts)	1600
Weight (Kg)	19

## Chapter 2. Warnings and Safety Instructions.

Read these instructions carefully before operating, maintaining or servicing this tool.  
Please keep these instructions in a safe accessible place.



Read to fully understand and observe the following safety precautions and warnings. Careless or improper use of this equipment may result in serious or fatal injury.



Always wear eye, head and ear protection equipment, when using this tool



### **WARNING!**

Indicates instant possibility of severe personal injury or loss of life, if instructions are not followed.



### **CAUTION!**

Indications a possibility of personal injury or equipment damage, if instructions are not followed.

### **Operator Safety**

- Always read the instructions carefully so as to avoid any injury or damage when unfamiliar with this equipment.
- Always wear a safety face shield or goggles.
- Wear ear defenders when using this equipment.
- Always wear heavy clothing, boots and gloves. Do not wear loose clothing, short pants, sandals etc. and ensure that long hair is tied up above shoulder length.
- Do not operate this equipment when tired, ill or under the influence of alcohol, drugs or medication.
- Never allow an inexperienced person operate this equipment.
- Never operate the equipment in damp, or water logged area.
- Keep all carrying handles and levers free from oil.

### **Tool Safety**

- Inspect the entire piece of equipment before use.
- Replace damaged components, lubricate where necessary and ensure that all fasteners are secure.
- Always use a safety chain to secure the equipment when it is being used above the ground.
- Use only accessories that have been recommended by the manufacturer. Failure to do so could result in damage to the tool and may invalidate the warranty.



### **WARNING!**

Never modify the tooling any way. Do not use your equipment for any job other than for which it is intended.

- Keep hands away from the cutter when it is rotating. Ensure that it has stopped rotating and is disconnected from the power source before touching the cutter.
- Do not attempt to gain access into the electrical panel. There is risk of electrical shock.
- Never use a larger diameter cutter than specified for use with this equipment.
- Do not attempt to connect the equipment to a power source other than that specified by the manufacturer.
- Ensure that the cutter being used is sharp and free from damage.

### **Maintenance safety**

- Maintain according to the manufacturers recommended procedures.
- Disconnect the equipment from the power source before attempting any maintenance.
- Use only genuine replacement components as recommended by the manufacturer.

### **Transport and Storage**

- Before moving the tool, ensure that the cutter has stopped rotating.
- Carry the tool with the cutter pointing away from the body to avoid laceration.
- After use, clean the equipment and it's accessories and store in a dry place.
- Store the equipment along with the maintenance tools in its correct carrying case when not in use.

## Chapter 3. Operating Instructions.



Ensure that the unit is disconnected from the power before working on the machine.

- **Insert Pilot Pin.**

The pilot pin is used to align the cutter and eject the slug on completion of the cut.

Slide the pilot through the hole in the centre of the cutter shank.



- **Fit the Cutter.**

Two grub screws are used to secure the cutter to the arbor. The cutter shank has two flats that must be aligned with the grub screws in the arbor.

Insert the cutter shank into the arbor. The screws must be tightened evenly so that the cutter is prevented from moving. The screws are tightened using the **5mm** Allen key supplied.

(A cutter with a shank diameter of 19.05mm/ $\frac{3}{4}$ " and cutting diameter of no larger than 100mm must be used).



- **Mark the centre of the required hole.**

- **Position the Machine.**

Ensure that the workpiece is clean and flat. Position the machine by aligning the pilot with the holes centre mark.

- **Fit the safety chain.**

- **Connect the machine to the power source.**

Switch on the power by depressing the RED power switch on the side panel.



- **Energise the magnet.**

Switch on the magnetic base by depressing the YELLOW magnet switch.

CHECK that the pilot is still aligned with the hole centre mark, as energising the magnetic base can cause the machine to move.



- **Apply Coolant**

A 500ml bottle of cutting oil is supplied with the machine. Using cutting oil can increase the tool life and ensures that the slug is ejected cleanly.

Fill or part fill the side mounted oil reservoir and turn on the tap at the bottom of the bottle. Fluid should now flow through the arbor and on to the cutter.

Check for fluid flow before you begin cutting and adjust the flow using the tap.

- **Start Cutting**

ALWAYS ENSURE THAT CUTTING GUARDS ARE IN PLACE.

Start the drill by depressing the GREEN drill switch.

Lower the cutter to the surface by turning the handle; and with light pressure cut an initial groove. Increase pressure until motor is loaded then maintain steady pressure until cut is complete.



VISO05 drill guard



- **Finish Cutting**

When the cut is complete the slug will be ejected from the cutter. Raise the cutter again; stop the motor and switch of the magnet.

- **Changing the Arbor**

To remove the arbor, insert drift into slot on drill head casing and tap lightly with a mallet.

**NOTE: –**

- Applying too much pressure will not speed the cut, it will reduce the life of the tool and may cause damage to the motor.
- If swarf becomes blue in colour then more cutting oil is required.
- If the power is interrupted during the cut, the magnet must be reset before the motor will restart.

## Chapter 4. Maintenance Instructions

- Occasionally apply a few drops of oil to the rack toothing.
- The bearings of the feed shaft are self-lubricating and must not be greased
- Grease the sliding surface of the carriage with MOLYCOTE grease.
- When not in use or being transported the unit should be kept in the case supplied.
- After use ensure unit is clean of swarf and dirt.
- Parts that are worn or damaged should be replaced immediately with original UNIBOR replacements.
- Ensure all cutting edges are sharp when in operation. Using blunt cutting tools may lead to an overload of the motor.
- After repeated use, the cradle may become loose. This is remedied by adjusting the tension screws on the side of the body. Put 2.5mm Allen Key into head of cradle retaining nuts, using 8mm Spanner undo the locking nuts anti-clockwise holding the Allen key without moving grub screws. Using the Allen Key gently tighten screws in series until the cradle moves freely in the slide but does not allow the motor to wobble. When adjustment is complete re-tighten locking nuts clockwise.



# Chapter 5. Exploded Views

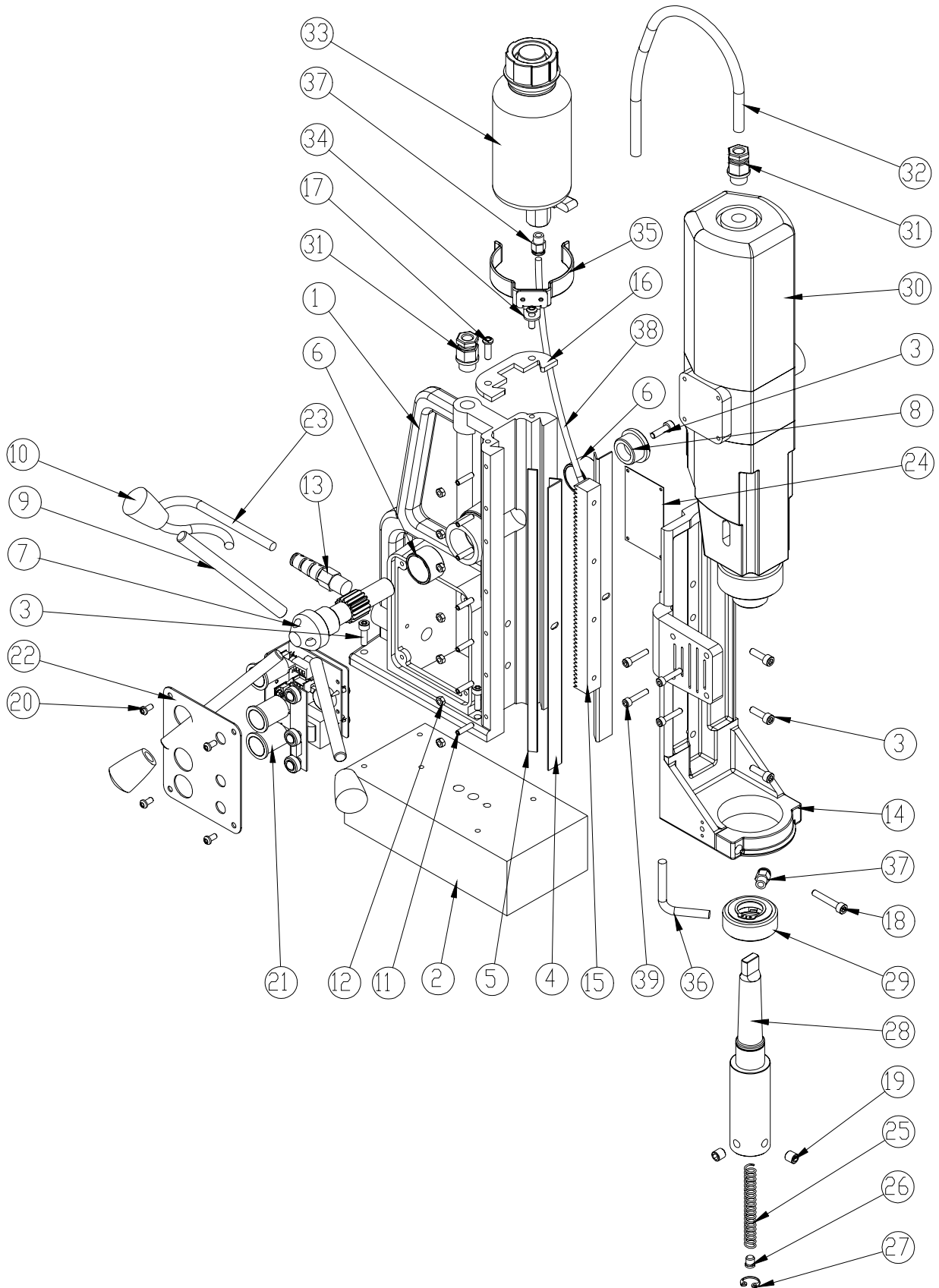

## Chapter 5. Component listing.

ITEM NO.	QTY.	PART NO.	DESCRIPTION
1	1	10061_1	BODY - UNIBOR 5023 - RED
2	1	M0033	MAGNET BASE - LARGE
3	8	SC620CAP	M6 X 20 CAP SCREW
4	2	60101A	BRASS STRIP ANGLED - UNIBOR
5	1	20387	G.F.S. - UNIBOR
6	2	M0081	BUSH (PINION)
7	1	M0042	PINION - MAGTRON (LARGE)
8	1	M0072	PINION END CAP (DEEP)
9	3	10081	HANDLE 12MM (SMALL)
10	3	10082	HANDLE KNOB (12MM KNOCK ON)
11	7	SC5GRUB	M5 X 20 LONG GRUB SCREW
12	7	NUT-M5	M5 NYLOC NUT
13	1	10231	M16 STRAIN RELIEF CABLE GLAND
14	1	cracas	CRADLE - CASELS
15	1	10075	RACK - UNIBOR
16	1	10084	TOP PLATE - UNIBOR
17	2	SC620BUT	M6 X 20 BUTTON HEAD SCREW
18	1	SC635CAP	M6 X 35 CAP SCREW
19	2	SC1010GRUB	M10 X 10 GRUB SCREW
20	4	SC510BUT	M5 X 10 BUTTON SCREW
21	1	PANELP	NEW PANEL - NO FACIA
22	1	20305N	UNIBOR SWITCH PLATE - NEW
23	1	CABL03	USA CABLE - 14 GAUGE
24	1	10101	WARNING PLATE - UNIBOR
25	1	spr101	ARBOR SPRING
26	1	10205a	ARBOR EJECTION PLUG
27	1	CCP-19	19MM INTERNAL CIRCLIP
28	1	ARBOIL8	ARBOR - OILFEED - No. 3 MORSE TAPER
29	1	oil03	MORSE TAPER OIL FEED RING
30	1	CASA01	DRILL - CASELS 110V
31	2	20354	CABLE GLAND - M16
32	1	10096	CONDUIT - GREY 10MM
33	1	OIL05	OIL CUP ASSEMBLY
34	1	10060	OIL CUP CLIP MOUNTING PLATE
35	1	10076	OIL CUP CLIP
36	1	M0045	COOLANT RING STOP - SHORT
37	2	50015B	DIA 6 PUSH FITTING
38	1	Oil Pipe	DIA 6 OIL PIPE
39	4	SC525CAP	M5 X 25 CAP SCREW

## Additional Parts (Not Shown)

ITEM NO.	QTY.	PART NO.	DESCRIPTION
-	1	DRIF02	DRIFT (No. 3 MORSE TAPER)
-	1	STRAP01	POLYESTER WEBBING SAFETY STRAP
-	1	OIL03	COOLCUT 500ML OIL BOTTLE
-	1	KEY01	ALLEN KEY 2.5MM
-	1	KEY02	ALLEN KEY 3MM
-	1	KEY03	ALLEN KEY 4MM
-	1	KEY04	ALLEN KEY 5MM
-	1	KEY05	ALLEN KEY 6MM
-	1	CASE14	CARRYING CASE - UNIBOR - PLASTIC
-	1	BOX01	BOX (UNIBOR SLEEVE)
-	1	VISO05	SAFETY GUARD S6032
-	2	10099	M6 X 16 GUARD THUMB SCREW
-	2	10094	M6 GUARD SPACER
-	2	10095	SMALL 2 LEG GUARD GUIDE

# PANEL COMPONENT LIST

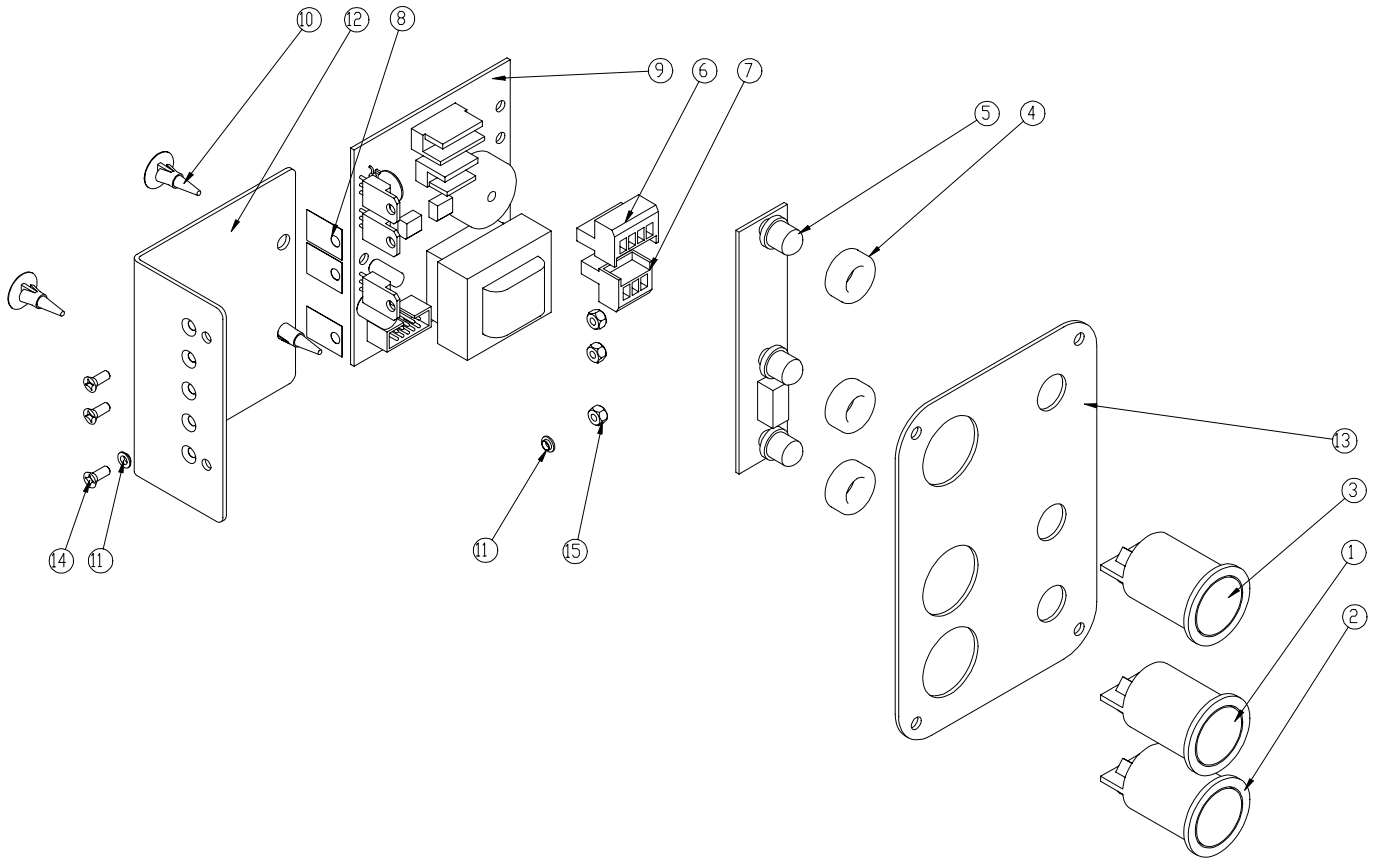

Item No.	Stock Code	Description	Quantity
1	MM1-1	MM1 MAGNET BUTTON - YELLOW	1
2	MM1-2	MM1 MOTOR BUTTON - GREEN	1
3	MM1-10	MM POWER BUTTON - RED	1
4	MM1-3	MM1 L.E.D. GROMMET	3
5	MM1-4	MM1 LED BOARD – C/W LEDs	1
6		<b>NO LONGER REQUIRED</b>	
7		<b>NO LONGER REQUIRED</b>	
8		<b>NO LONGER REQUIRED</b>	
9	IMI-MM1-5	REPLACEMENT PCB BOARD	1
10	MM1-16	STAND OFF CLIP FOR NEW PANEL	2
11		<b>NO LONGER REQUIRED</b>	
12	MM1-17	PCB SUPPORT PLATE	1
13	M0241B	SWITCH PLATE	1
14	SC316CSK-X	M3 x 16 PHILIPS HEAD SCREW	3
15	NUT-M3	M3 LOCK NUT	3

# Chapter 5. Electric Motor Break Down

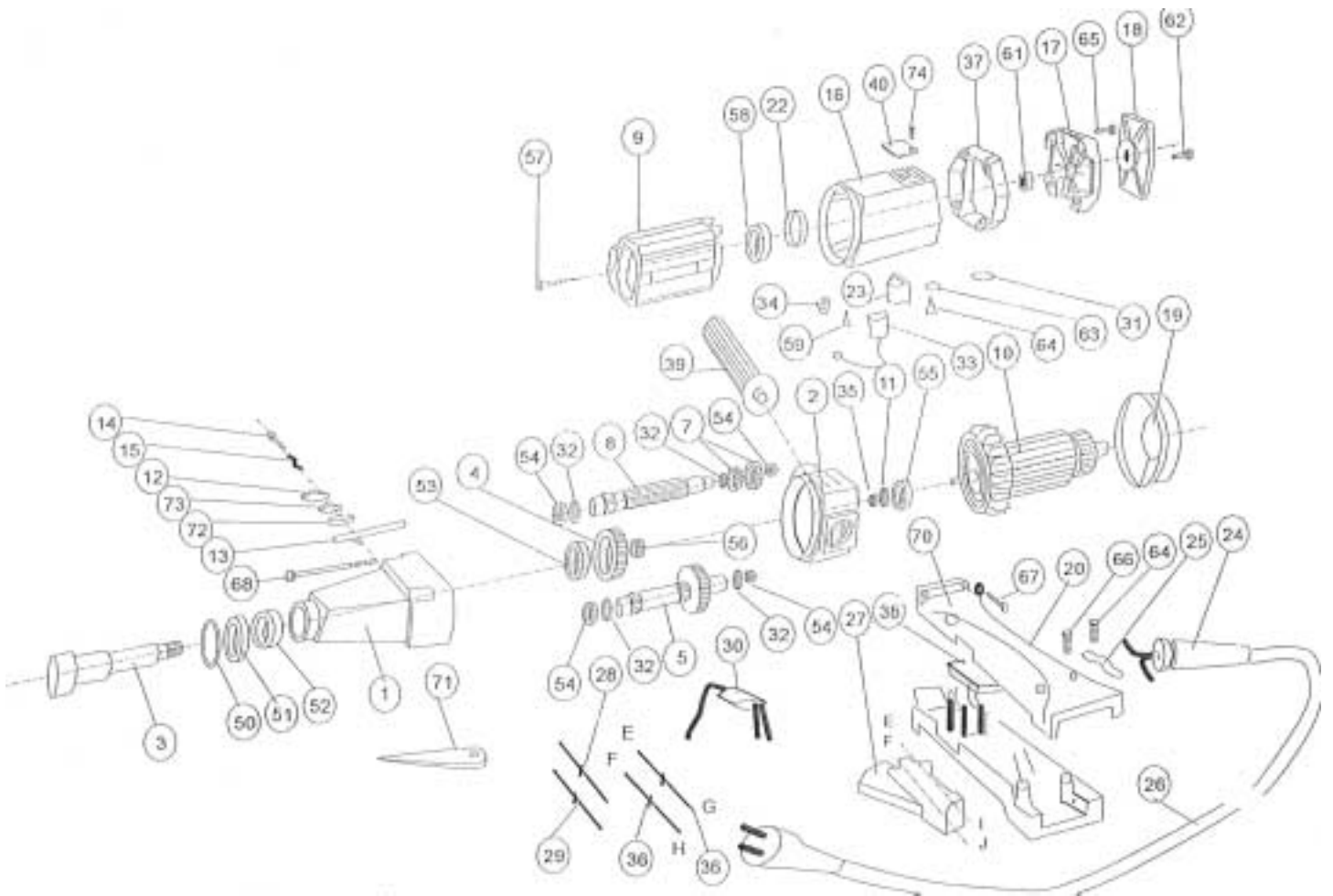

Item No.	VENDOR PART	PRICE	PART NO	Description	Item No.	VENDOR PART	PRICE	PART NO.	Description
1	CAS016		9002	GEAR BOX	33	CAS035		9072	CARBON BRUSHES
2	CAS017		1021	MID GEAR BOX	34	13413		2251	BRUSH SPRINGS
3	CAS018		3012	MT3 SPINDLE	35				FERRULE
4	CAS007		3021	MAIN DRIVE GEAR	36				CONNECTOR
5	CAS021		8511	TRIPLE GEAR	37	CAS044		6025	VARIABLE SPEED CONTROL
7	CAS019		3061	DOUBLE GEAR	38	13010		416	FOAM PAD
8			3051	TRAILER GEAR	39				SIDE HANDLE
9	CASFC3		9024 9026B	FIELD COIL 1600 WATT 1200 WATT	40				CARBON BRUSH COVER
10	CASA01		9033A	ARMATURE	50				OIL SEAL
11	13010		3451	OIL SEAL	51				THRUST BEARING
12	13121		3291	GEAR CHANGE HANDLE	52				NEEDLE BEARING
13	13121		3291	GEAR CHANGE SPINDLE	53				MAIN BEARING
14	13121		6201	GEAR CHANGE SCREW	54				NEEDLE BEARING
15	13121		3311	GEAR CHANGE SPRING	55				ARMATURE BEARING
16	CAS010		9011	FIELD COVER CASING	56				LOCK NUT
17	CAS024		1062	TOP COVER	57				SCREW
18	13121		5013	BREAST PLATE	58				END BEARING
19	13121		2613	FAN COVER	59				FFASTENER
					61				RETAINING NUT
22	CAS032		1601	BEARING CUP	62				FASTENER
23	13413		4231	BRUSH HOLDERS	63				WASHER
24	13413		10231	STRAIN RELIEF	64				FASTENER
25	13413		NUT-M5	CORD CLIP	65				FASTENER
26				MAINS CABLE	66				FASTENER
					67				HANDLE SCREW
28	76719		0352	CABLE CONNECTOR	68				FASTENER
29	76719		0369	CABLE CONNECTOR	70				WASHER
30	13831		5001	CONDENSER	71				MT3 DRIFT
					72				GASKET
32	CAS025		CAS025	THRUST WASHER	73				RETAINING COVER
					74				FASTENER

# Wiring Diagrams

COPYRIGHT (C)1998, UDCE LTD, 42, CATLEY ROAD, DARNALL, SHEFFIELD, S9 5JF  
 THIS DRAWING MAY NOT BE REPRODUCED OR COPIED IN PART OR WHOLE,  
 WITHOUT THE EXPRESS PERMISSION OF UDCE LTD.

FIRST ANGLE PROJECTION DO NOT SCALE IF IN DOUBT - ASK

ISSUE	DESCRIPTION	DATE

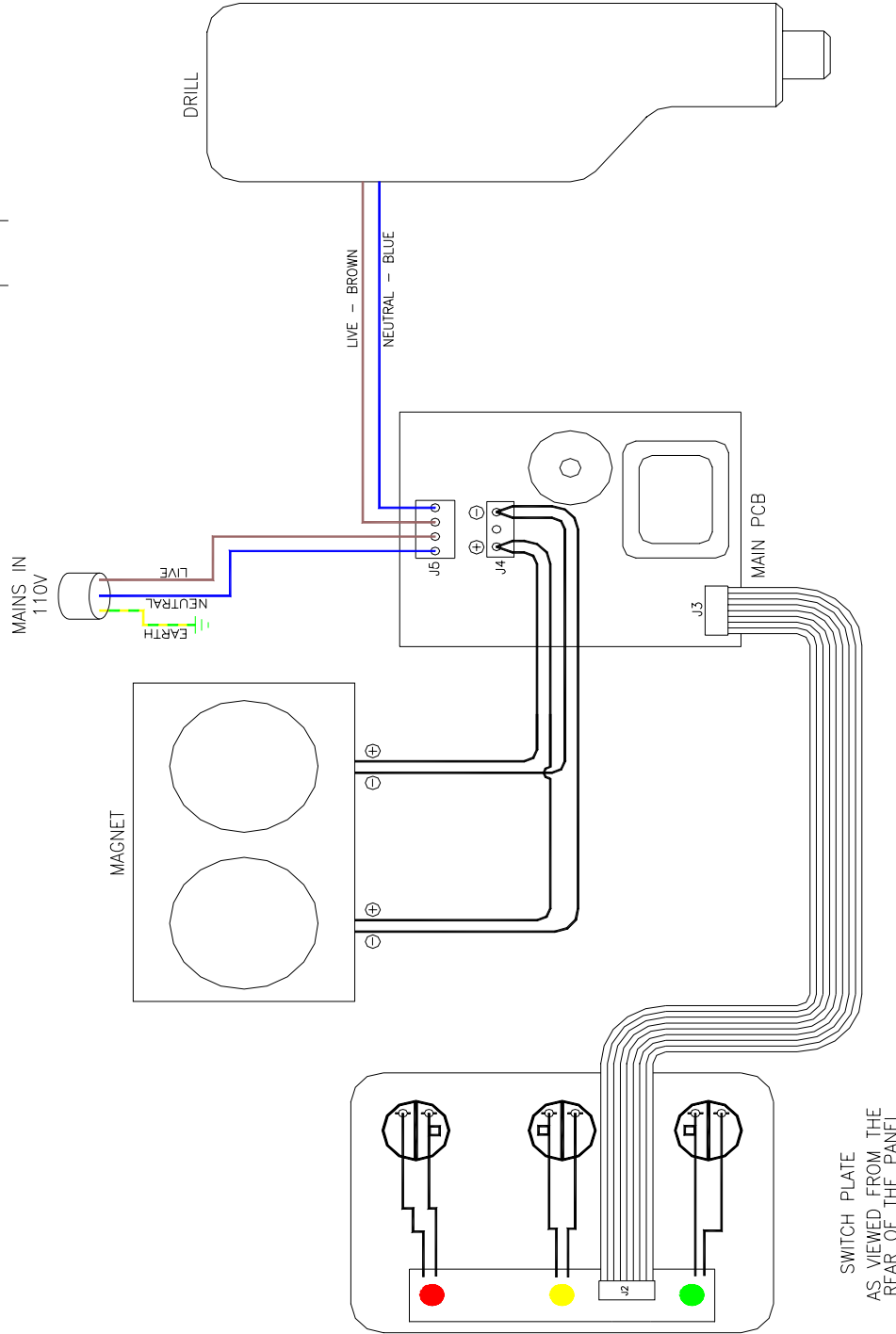

SWITCH PLATE  
 AS VIEWED FROM THE  
 REAR OF THE PANEL

TITLE	SCALE	ISSUE	DATE
WIRING SCHEMATIC	--	1	11.07.02
PANELP	J.LEES	DATE	DATE
110V	APPROVED BY	DATE	DATE
	DWG NUMBER	PANELP110V	

**universal** Drilling & Cutting  
 EQUIPMENT LIMITED  
 43 Catley Road, Darnall, Sheffield, England, S9 5JF. Tel: +44 (0)114 291 1000. Fax: +44 (0)114 242 5905.