

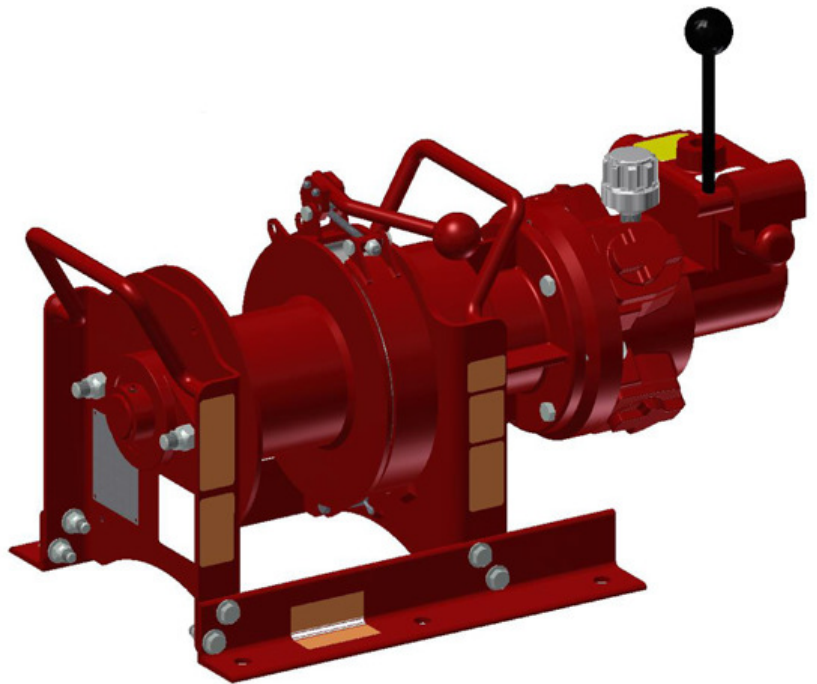

Read this Owner's Manual thoroughly before operating the equipment. Keep it with the equipment at all times. Replacements are available from Thern, Inc., PO Box 347, Winona, MN 55987, 507-454-2996. [www.thern.com](http://www.thern.com)

**IMPORTANT:** Please record product information on page 2. This information is required when calling the factory for service.



# Owner's Manual

## For MTA.5-S and MTA1-S Series Cycloidal Gear Air Winches

## Warranty Statement

Please record the following:

Date Purchased: \_\_\_\_\_

Model No.: \_\_\_\_\_

Serial No.: \_\_\_\_\_

This information is required when calling the factory for service.

Thern, Inc. warrants each new products to be free from defects in material and workmanship under normal use and service for a period of 24 months from the date of purchase by the original using buyer. Genuine Thern, Inc. replacement parts and components will be warranted for 30 days from the date of purchase, or the remainder of the original equipment warranty period, whichever is longer.

Under no circumstances will this warranty cover a product or component thereof, which, in the opinion of the company, has been subjected to misuse, unauthorized modifications, alteration, an accident or shipping damage. This warranty also shall not apply to products that are operated improperly, improperly maintained or improperly stored.

This warranty does not cover any costs for removal of our product, downtime, or any other incidental or consequential costs or damages resulting from the claimed defects. Brake discs, wire rope or other wear components are not covered under this warranty, as their life is subject to use conditions which vary between applications. Any alteration, repair or modification of the product outside the Thern, Inc. factory shall void this warranty.

Thern, Inc. in no way warrants pneumatic, hydraulic or electric motors and control valves or other trade accessories since these items are warranted separately by their respective manufacturers.

FACTORY AUTHORIZED REPAIR OR REPLACEMENT AS PROVIDED UNDER THIS WARRANTY IS THE EXCLUSIVE REMEDY TO THE CONSUMER. THERN, INC. SHALL NOT BE LIABLE FOR ANY INCIDENTAL OR CONSEQUENTIAL DAMAGES FOR BREACH OF ANY EXPRESS OR IMPLIED WARRANTY ON THIS PRODUCT. EXCEPT TO THE EXTENT PROHIBITED BY APPLICABLE LAW, ANY IMPLIED WARRANTY OF MERCHANTABILITY OR FITNESS FOR A PARTICULAR PURPOSE ON THIS PRODUCT IS LIMITED IN DURATION TO THE DURATION OF THIS WARRANTY.

Some states do not allow the exclusion or limitation of incidental or consequential damages, or allow limitations on how long an implied warranty lasts, so the above limitation or exclusion may not apply to you. This warranty gives you specific legal rights, and you may also have other rights which vary from state to state.

**To make a claim under this warranty, contact the factory for an RGA number. The product must be returned, prepaid, directly to Thern, Inc. or to an authorized service center. A completed warranty claim form must accompany the product. If the product is found to be defective, it will be repaired or replaced free of charge, and Thern, Inc. will reimburse the shipping costs.**

**Note: Thern, Inc. reserves the right to change the design or discontinue the production of any product without prior notice.**

## About This Manual

The Occupational Safety and Health Act of 1970 states that it is the employer's responsibility to provide a workplace free of hazard. To this end, all equipment should be installed, operated, and maintained in compliance with applicable trade, industrial, federal, state, and local regulations. It is the equipment owner's responsibility to obtain copies of these regulations and to determine the suitability of the equipment to its intended use.

This Owner's Manual, and warning labels attached to the equipment, are to serve as guidelines for hazard-free installation, operation, and maintenance. They should not be understood to prepare you for every possible situation.

The information contained in this manual is applicable only to the Thern MTA.5-S and MTA1-S Series Cycloidal Gear Air Winches. Do not use this manual as a source of information for any other equipment.

The following symbols are used for emphasis throughout this manual:

### **▲WARNING**

Failure to follow 'WARNING!' instructions may result in equipment damage, property damage, and/or serious personal injury.

### **▲CAUTION**

Failure to follow 'CAUTION!' instructions may result in equipment damage, property damage, and/or minor personal injury.

**Important!**

Failure to follow 'important!' instructions may result in poor performance of the equipment.

Figure 1 – Serial Tag

○		THERN, INC.		○		
		PO BOX 347				
		WINONA, MN 55987				
		(507) 454-2996				
MODEL #	<input type="text"/>					
SERIAL #	<input type="text"/>					
1ST LAYER RATING (LBS)	<input type="text"/>					
MID DRUM RATING (LBS)	<input type="text"/>					
FULL DRUM RATING (LBS)	<input type="text"/>					
1ST LAYER SPEED (FPM)	<input type="text"/>					
MID DRUM SPEED (FPM)	<input type="text"/>					
FULL DRUM SPEED (FPM)	<input type="text"/>					
DRUM SIZE (IN.)	ID	<input type="text"/>	OD	<input type="text"/>	W	<input type="text"/>
ROPE SIZE (IN.)	<input type="text"/>					
VOLTAGE	<input type="text"/>					
PRESSURE	<input type="text"/>	FLOW	<input type="text"/>			
CODE #	<input type="text"/>					
 <b>WARNING READ OWNERS MANUAL</b> NOT FOR LIFTING PEOPLE OR THINGS OVER PEOPLE						
○		PART # A5923		○		

Figure 1A - Serial Tag Location



## Suggestions for Safe Operation

### **⚠WARNING**

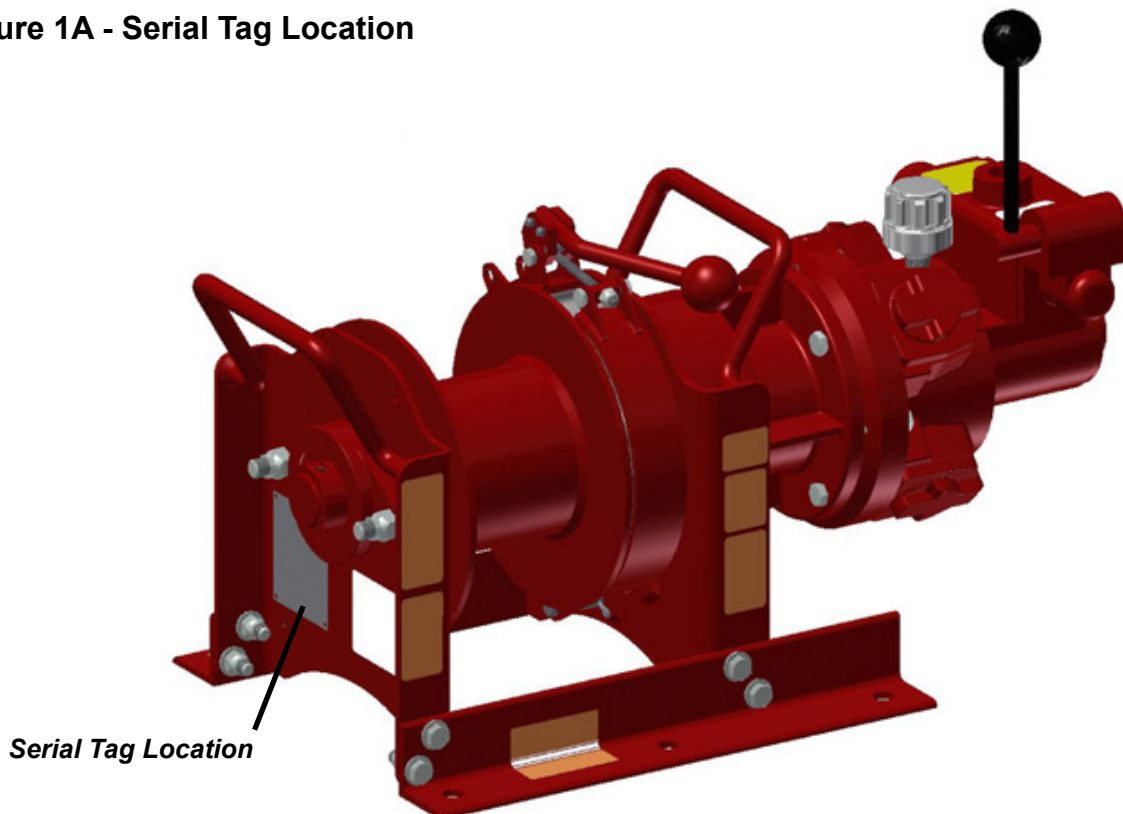
#### **DO the following:**

Read and comply with the guidelines set forth in this Owner's Manual. Keep this manual, and all labels attached to the winch, readable and with the equipment at all times. Contact Thern, Inc. for replacements.

Check lubrication before use.

Install the wire rope securely to the winch drum.

Keep at least 5 wraps of wire rope wound on the drum at all times, to serve as anchor wraps. With less than 5 wraps on the drum the wire rope could come loose, causing the load to escape.

Keep hands away from the drum, gears, wire rope, and other moving parts of the equipment.

Ensure brakes hold prior to making complete lift by lifting load a short distance and releasing control.

If there is slack wire rope condition, the hoisting mechanisms shall be inspected to ensure all wire ropes are properly seated on drums and in sheaves, before resuming winch operation.

Disconnect air supply and bleed off pressure before servicing the equipment.



---

## Suggestions for Safe Operation

**⚠WARNING****DO NOT do the following:**

**Do not lift people or things over people. Do not walk or work under a load or in the line of force of any load.**

**Do not exceed the load rating of the winch or any other component in the system. To do so could result in failure of the equipment.**

**Do not use more than one winch to move a load unless each winch was designed for use in a multiple winch system.**

**Do not use damaged or malfunctioning equipment. To do so could result in failure of the equipment.**

**Do not modify the equipment in any way. To do so could cause equipment failure.**

**Do not wrap the wire rope around the load. This damages the wire rope and could cause the load to escape. Use a sling or other approved lifting device.**

**Do not operate the winch with drive guards or gear covers removed or improperly installed.**

**Do not divert your attention from the operation. Stay alert to the possibility of accidents, and try to prevent them from happening.**

**Do not jerk or swing the load. Avoid shock loads by starting and stopping the load smoothly. Shock loads overload the equipment and may cause damage.**

**Do not leave a suspended load unattended unless specific precautions have been taken to secure the load and keep people away from the winch and out from under the load.**

**Do not adjust the brake with the load suspended.**

## 1.1 Installing the Winch

### Important!

- Inspect the winch immediately following installation according to Section 3.3.4 - Instructions for Periodic Inspection. This will give you a record of the condition of the winch with which to compare future inspections.
- A qualified professional should inspect or design the foundation to insure that it will provide adequate support.
- Locate the winch so it will be visible during the entire operation.
- When moving and positioning the winch, lift using the lifting eyes or handles in the frame or with a sling wrapped around drum.
- Do not weld the winch frame to the foundation or support structure. Welding the frame may void warranty, contact Thern, Inc. Use fasteners as instructed.

### ⚠WARNING

All supporting structure, mounting hardware and attaching hardware must be in accordance with all applicable standards codes and regulations.

Ensure proper selection and installation of wire rope and sheaves. Sheaves and sheave mounting must be designed and selected in accordance with all applicable standards, codes, and regulations. Improper installation of wire rope or sheave can cause uneven spooling and wire rope damage that could cause a load to escape.

Do not install the winch in an area defined as hazardous by the National Electric Code, unless installation in such an area has been thoroughly approved.

Do not install the winch near corrosive chemicals, flammable materials, explosives, or other elements that may damage the winch or injure the operator. Adequately protect the winch and the operator from such elements.

Position the winch so the operator can stand clear of the load, and out of the path of a broken wire rope that could snap back and cause injury.

Attach the winch to a rigid and level foundation that will support the winch and its load under all load conditions, including shock loading.

### Important!

- Use a sheave or roller guide to direct the wire rope to the drum whenever possible.
- Install sheaves, tracks and other equipment so they will remain fixed under all load conditions. Follow the recommendations of the equipment manufacturer.
- Use sheaves of proper diameter to minimize wear on the wire rope. Follow the recommendations of the sheave manufacturer.

**Figure 2 – Maintaining the Fleet Angle**

- When wire rope travels over a sheave or through a roller guide – maintain fleet angle by locating the sheave or guide an appropriate distance from the drum, shown as distance “A”.

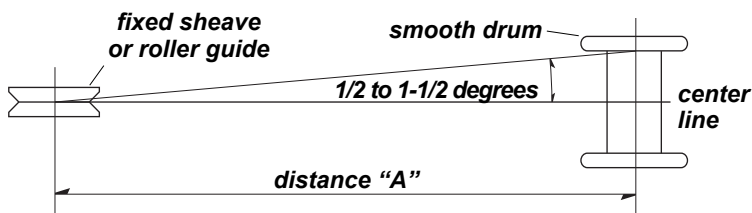

- When wire rope travels directly to the load – maintain fleet angle by controlling side-to-side movement of the load with tracks or guide rails. Allowing the load to move too far to one side causes stress on the drum flange which may cause damage.

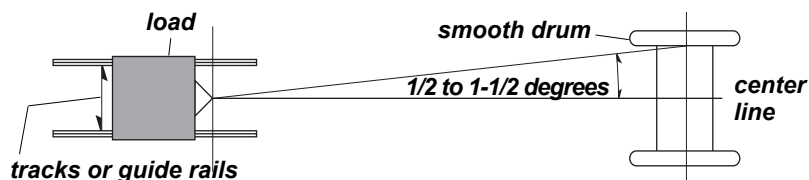

- 1.1.1 CONSULT APPLICABLE CODES AND REGULATIONS for specific rules on installing the equipment.
- 1.1.2 LOCATE THE WINCH in an area clear of traffic and other obstacles. Make sure the winch is accessible for maintenance and operation.
- 1.1.3 LOCATE THE WINCH in an area with adequate temperatures (-4° to 122°F). Check the motor and reducer manufacturer's information for ambient temperature ratings.
- 1.1.4 INSTALL THE WINCH on a horizontal surface. The winch is designed and assembled for horizontal base mounting. Special consideration must be taken if mounting vertically or upside-down. Please contact Thern, Inc.
- 1.1.5 MAINTAIN A FLEET ANGLE between 1/2 and 1-1/2 degrees. The proper fleet angle minimizes wire rope damage by helping the wire rope wind uniformly onto the drum. See Figure 2.
- 1.1.6 FASTEN THE WINCH SECURELY to the foundation.
  - a FOR STANDARD PRODUCTS referred to in this manual, use coarse thread fasteners, grade 5 or better. Be sure to check the torque required for your fastener selection before mounting winch. Make sure the winch is secured to a solid foundation able to support the winch and the load under all conditions with design factors based on accepted engineering practices.
  - b NON-STANDARD PRODUCTS that vary from the original design may have different fastening requirements. Contact a structural engineer or Thern, Inc. for this information.

CONTACT A QUALIFIED PROFESSIONAL FOR MOUNTING INSTRUCTIONS TO COMPLY WITH LOCAL CODES.

## 1.2 Installing the Breather Plug

### **⚠ CAUTION**

Make sure the breather plugs are clean and open to vent heat and pressure. Poor ventilation will cause overheating and result in damage to oil seals and other equipment. See Figures 3a and 3b.

For shipment, the winch motor and reducer are filled with lubricant and motor and MTA1-S reducer breather plugs installed.

- 1.2.1 VERIFY THE BREATHER PLUG is installed on the motor and MTA1-S reducer. Refer to the motor and reducer manufacturer's information. MTA.5-S reducers are grease packed and sealed. This reducer does not require oil fill or breather plugs.
- 1.2.2 CHECK THE LUBRICANT LEVEL in the motor and MTA1-S reducer to make sure no lubricant was lost during shipment. See section 3.2 - Lubricating the Winch.

**Figure 3a – Installing the Breather Plug MTA.5-S**

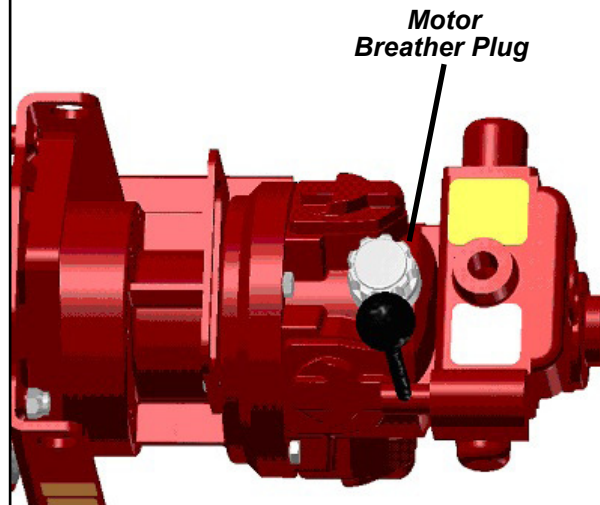

**Figure 3b – Installing the Breather Plug(s) - MTA1-S**

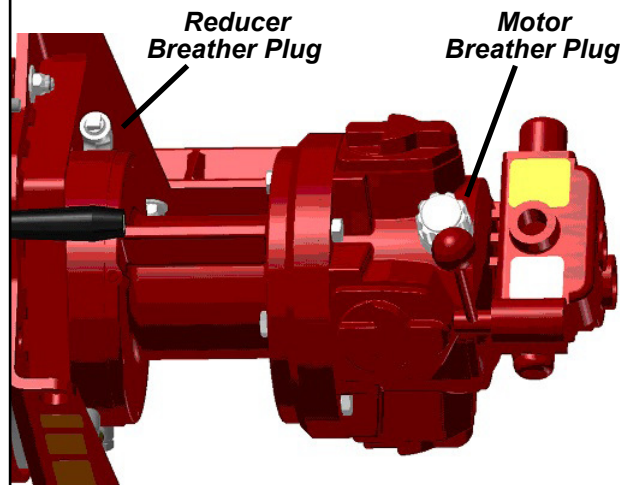



## 1.3 Connecting the Air Supply

### Important!

- Use components rated for the power supply you will be using.
- Always disconnect the air supply when the winch is not in use. When removing the air hoses from the unit, plug the open ports.
- The F-R-L must be compatible with the required air supply.

### **⚠WARNING**

**Check that the direction indicators on control match load direction.**

**Remove port caps from exhaust ports for operation. Failure to do so may result in equipment damage and limit performance. See Figure 8 on page 17.**

**All control devices must be momentary type. Install all control devices so the winch motor will stop when the operator releases the device.**

**Locate control devices so the operator will be able to view the load through the entire operation.**

**Locate control devices so the operator will be clear of the load, the wire rope, and the path of a broken wire rope that could snap back and cause injury.**

It is the responsibility of the owner to provide equipment for controlling the winch. The following guidelines are supplied as a reference for the installer.

**INSTALL A F-R-L ON YOUR UNIT BEFORE WINCH OPERATION. A FILTER-REGULATOR-LUBRICATOR UNIT MUST BE USED WHILE OPERATING EQUIPMENT TO MAINTAIN WARRANTY. THERN WILL NOT COVER ANY DAMAGE TO EQUIPMENT CAUSED BY DIRTY, POOR, CONTAMINATED OR NON-LUBRICATED AIR SUPPLY. SEE FIGURE 5.**

- 1.3.1 CONSULT APPLICABLE CODES AND REGULATION for specific instructions regarding air supply installation and backup.
- 1.3.2 CHECK THE COMPONENT MANUFACTURER'S INSTRUCTIONS for installing and connecting the motor and other equipment.
- 1.3.3 ENSURE an accessible shut off valve has been installed in the air supply line and make sure others are aware of its location.
- 1.3.4 THE AIR SUPPLY must be clean and free from moisture.
  - a ALL AIR SUPPLY LINES should be purged with clean, moisture free air or nitrogen before connecting to winch inlet.
  - b SUPPLY LINES should be as short and straight as installation conditions will permit. Long transmission lines and excessive use of fittings, elbows, tees, globe valves etc. cause a reduction in pressure due to restrictions and surface friction in the lines.
- 1.3.5 ALWAYS USE an air line lubricator with these motors.
  - a THE LUBRICATOR must have an inlet and outlet at least as large as the inlet on the motor. Install the air line lubricator as close to the air inlet on the motor as possible.
  - b LUBRICATOR must be located no more than 10 ft. (3 m) from the motor.
  - c AIR LINE LUBRICATOR should be replenished daily and set to provide 6 to 9 drops per minute of SAE 10W oil. A fine mist will be exhausted from the throttle control valve when the air line lubricator is functioning properly.

**Figure 4 – Mufflers**

*Muffler installed in valve exhaust port*

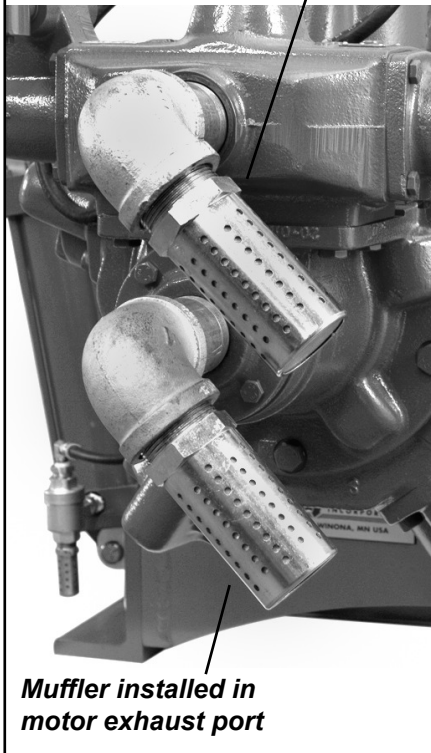

*Muffler installed in motor exhaust port*

- 1.3.6 IT IS RECOMMENDED that an air line strainer/filter be installed as close as practical to the motor air inlet port, but before the lubricator, to prevent dirt from entering the motor. The strainer/filter should provide 20 micron filtration and include a moisture trap. Clean the strainer/filter periodically to maintain its operating efficiency.
- 1.3.7 MOISTURE THAT REACHES THE AIR MOTOR through air supply lines is a primary factor in determining the length of time between service overhauls.
  - a MOISTURE TRAPS can help to eliminate moisture.
  - b AIR RECEIVERS collect moisture before it reaches the motor.
  - c INSTALLING AN AFTERCOOLER at the compressor that cools the air to condense and collect moisture prior to distribution through the supply lines is also helpful.
- 1.3.8 THE AIR MOTOR SHOULD BE INSTALLED as near as possible to the compressor or air receiver. Recommended pressures and volumes are measured at the point of entry to the air motor.
- 1.3.9 INSTALL MUFFLERS in both exhaust ports to reduce noise. See Figure 4.
- 1.3.10 CHECK THE AIR PRESSURE at the regulator and make sure it agrees with the pressure rating marked on the winch nameplate.
- 1.3.11 TEST AIR CONNECTIONS by slowly opening the air line to ensure air connections are sound prior to moving load. Then gradually operate the winch.
  - a ROTATION OF THE DRUM must agree with the labels on the control device, either UP and DOWN, or FORWARD and REVERSE.

CONTACT THE FACTORY OR A QUALIFIED PROFESSIONAL FOR HELP.

**Figure 5 – Filter-Regulator-Lubricator Unit (F-R-L)**

*PSI gauge installed on regulated lubricator side*

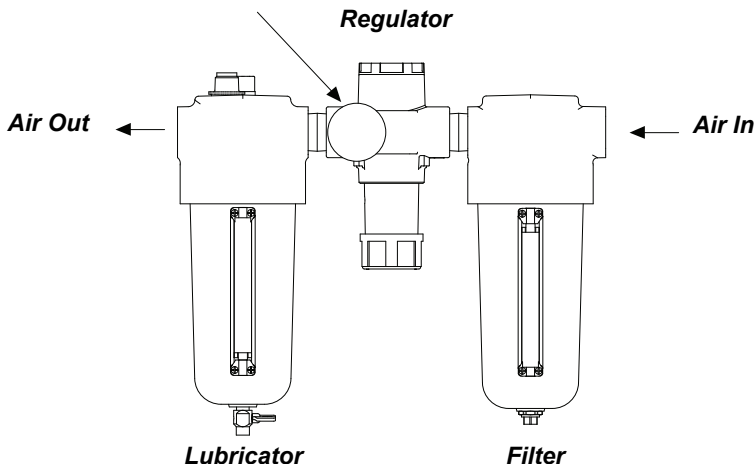

## 1.4 Installing the Wire Rope

### Important!

- Use wire rope and other rigging equipment rated for the size of the largest load you will be moving.
- Do not drag the wire rope through dirt or debris that could cause damage, or poor operation.
- Always wear protective clothing when handling wire rope.

### ⚠WARNING

**Install the wire rope securely to the winch drum. A poorly secured wire rope could come loose from its anchor and allow the load to escape.**

**Install the wire rope so it is wound correctly as shown or the winch and brake will not work properly, and could allow the load to escape. See Figure 6B.**

Inspect wire rope prior to installation. See Section 3.3.4.

**Figure 6A – Installing the Wire Rope – Recessed Anchor**

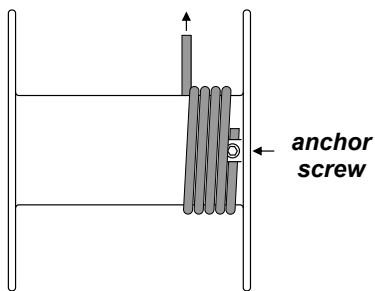

**correct**

**typical installation shown right lay – underwound**

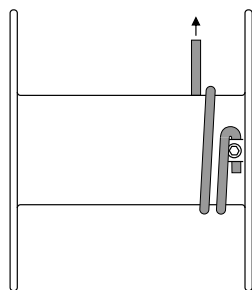

**incorrect**

1.4.1 DETERMINE WHICH DIRECTION the drum must rotate to wind and unwind wire rope. See Figure 6B.

1.4.2 PURCHASE THE PROPER WIRE ROPE for your application. Keep the following in mind when selecting a wire rope. Contact a reputable wire rope supplier for help.

a BREAKING STRENGTH of new wire rope should be at least 3 times greater than the largest load placed on the winch. If loads are lifted or pulled on an incline, the breaking strength must be at least 5 times greater than the largest load. These are minimum values and will vary with the type of load and how you are moving it.

b WIRE ROPE LAY must agree with the winding direction of the drum to help insure proper winding.

c WE RECOMMEND 7 x 19 galvanized aircraft cable for diameters up to 5/16 inch, and 6 x 37 IWRC improved plow steel (IPS) or extra improved plow steel (EIPS) wire rope for diameters of 3/8 inches and up.

1.4.3 ANCHOR THE WIRE ROPE to the drum using the block anchor. See Figure 6A.

a PASS THE WIRE ROPE through the hole in the anchor block. Make sure at least 1/2 inch of wire rope extends past the set screw, and the end of the wire rope does not protrude out where it will hit other components as the drum is turning.

b TIGHTEN THE SETSCREW in the anchor block to securely hold the wire rope in place.

1.4.4 WIND FIVE FULL WRAPS of wire rope onto the drum by operating the winch while holding the wire rope taut. These wraps serve as anchor wraps and must remain on the drum at all times.

**Figure 6B – Wire Rope Wrap Direction**

**shown with wire rope in the underwound configuration**

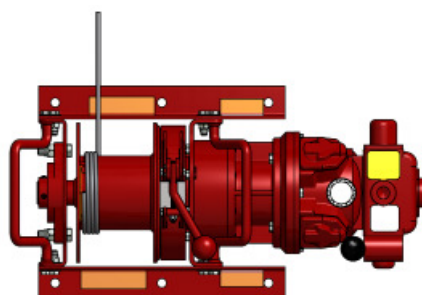

**Note: make sure wire rope is underwound**



## 2.1 General Theory of Operation

### Important!

- Limit nonuniform winding by keeping tension on the wire rope and by maintaining the proper fleet angle.
- To help ensure rated performance, make sure the air pressure at the motor is equal to the winch's pressure rating.
- It is your responsibility to detect and account for different factors affecting the condition and performance of the equipment.
- When determining whether the load will exceed the load rating, consider the total force required to move the load.

- 2.1.1 THE FORCE REQUIRED to move the load must not exceed the load rating of the winch. Consider the total force required to move the load, not the weight of the load.
- 2.1.2 THIS EQUIPMENT CAN develop forces that will exceed the load rating. It is the responsibility of the equipment user to limit the size of the load. Inspect the equipment regularly for damage according to the instructions contained in this manual and in the component manufacturer's information.
- 2.1.3 USE A LOAD BRAKE on all winches used to lift loads or drag loads on an incline. When manually engaged, it locks the drive train to the winch frame, thereby stopping drum rotation when the control is released or placed in the neutral position.
- a WHEN OPERATING REMOTELY with only a manual band brake, an operator must be present at winch for manual operation of band brake.
- 2.1.4 PERFORMANCE RATINGS of the equipment are affected by the amount of wire rope wound on the drum, the way in which it is wound, air power supply, and the way the winch is used.
- a DRUM CAPACITY depends on how tightly and evenly the wire rope is wound on the drum. Actual drum capacities are usually 25-30% less than values shown in performance tables, due to loose winding and overlapping.
- b LINE SPEED increases with each additional layer of wire rope wound onto the drum. Line speed will also vary with load weight and air power supply.
- c LOAD RATING represents the maximum load/force that can be placed on new equipment. Load ratings are assigned values for specific amounts of load travel or wire rope accumulation. The load rating decreases as layers of wire rope accumulate on the drum, as is described on the serial tag.
- 2.1.5 DUTY RATINGS refer to the type of use the equipment is subject to. Consider the following when determining duty rating.
- a ENVIRONMENT: harsh environments include hot, cold, dirty, wet, corrosive, or explosive surroundings. Protect the equipment from harsh environments when possible.
- b MAINTENANCE: poor maintenance, meaning poor cleaning, lubrication, or inspection, leads to poor operation and possible damage of the equipment. Minimize poor maintenance by carefully following the instructions contained in this manual.
- c LOADING: severe loading includes shock loading and moving loads that exceed the load rating of the equipment. Avoid shock loads, and do not exceed the load rating of the equipment.
- d FREQUENCY OF OPERATION: frequent start and stop functions increase wear and shorten the life span of the gear train and load brake components. Lengthy operations cause lubrication to become hot, which also decreases the life span of the gear train and brakes. Increase maintenance of the equipment if used in frequent operations.

CONTACT FACTORY FOR MORE INFORMATION.

## 2.2 Inspecting/Adjusting the Brake

**Figure 7 – MTA.5 & MTA1  
Manual Band Brake  
Adjustment**

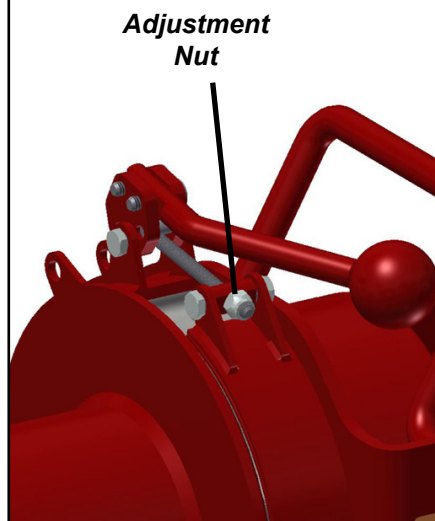

### **⚠WARNING**

Brake surfaces become hot during operation. Do not touch hot surfaces and be sure to wear protective gloves.

Do not adjust brake with the winch holding a load. Accidental release of the brake could allow the load to escape.

Keep hands away from the drum, gears, wire rope and other moving parts of the equipment.

#### 2.2.1 INSPECTING THE BAND BRAKE

- a DRUM BAND BRAKE should be inspected for oil, grease and glazing. These occurrences are not uncommon but need to be fixed before operation continues. If the brake lining is oil-soaked, replace the brake band. A fine grit emery cloth should be used to sand any glazed area to remove them.
- b MEASURE BAND THICKNESS to maintain brake effectiveness. Brake band must be replaced before band brake wears through. It is recommended to replace the band brake before the brake material measures less than .015 inch thickness at any given point.

2.2.2 TEST BRAKE to ensure proper operation. At first layer, the brake adjustment shall be set to hold a minimum static load of 125% first layer load rating without slipping. (See product nameplate for first layer rating). This will provide proper operation at 100% load dynamic. Check all brake surfaces for wear, deformation, or foreign deposits. If poor operation or visual damage is witnessed, contact factory and have brake repaired.

#### 2.2.3 ADJUSTING THE BAND BRAKE

- a MAKE SURE there is no load on the winch.
- b RELEASE WIRE ROPE TENSION on the drum.
- c RELEASE TENSION OF BRAKE BANDS by disengaging the brake band handle.
- d ROTATING THE ADJUSTMENT NUT clockwise will tighten the brake band. Adjustments should be made in increments of 1/8 rotation. See Figures 7.
- e CHECK THE ADJUSTMENT by engaging the band brake. The brake is properly adjusted when it takes between 4 and 6 lbs of force being applied to the handle to be pushed into the locked position (handle over center) with no load on the winch. If not, repeat step "d" until correct.

---

## 2.3 Breaking-In The Winch

### **⚠WARNING**

**Remove exhaust port caps for operation if applicable. Failure to do so may result in equipment damage and limit performance. See Figure 8.**

- 2.3.1 BEFORE THE WINCH IS PLACED INTO SERVICE or for winches that have been in storage for a period of more than one month, the following start-up procedure is required. See Figure 8.
- a INSPECT THE WINCH and other equipment according the Instructions for Periodic Inspection.
  - b WHEN FIRST OPERATING THE WINCH it is recommended that the motor be driven slowly in both directions for a few minutes.
  - c ENSURE BRAKE HOLDS prior to making complete lift by lifting load a short distance and releasing control.
- 2.3.2 PRIOR TO INITIAL USE, all new, altered or repaired winches shall be tested to ensure proper operation. See Figure 8 and Section 3.2 - Lubricating the Winch.
- a CHECK THAT THE OIL LEVEL in motor and the MTA1-S reducer is correct.
  - b ALL NEW DRUM BRAKE BAND LININGS require a "run-in" period. Operate the winch without load in the payout direction while gradually applying the brake. Allow the brake to slip for approximately one minute. Winch motor may stall as drum brake band lining fully engages. **Do not allow brake to overheat. Look for signs of overheating (smoke, hot to touch, burnt paint, etc.) Check operation of brake following run-in. See Section 2.2 - Inspecting/Adjusting the Brake**
- 2.3.3 INSPECT THE WINCH following the break-in according to the Instructions for Periodic Inspection. See Section 3.3 - Inspecting the Equipment.

---

## 2.4 Preparing for Operation

**⚠WARNING**

Read and comply with the guidelines set forth in this Owner's Manual. Keep this manual accessible to operators at all times, and all labels attached to the winch, readable and with the equipment at all times. Contact Thern, Inc. for replacements.

**Do not lift people or things over people. Do not walk or work under a load or in the line of force of any load.**

**Do not exceed the load rating of the winch or any other component in the system. To do so could result in failure of the equipment.**

**The winch must be equipped with a load brake if it is used to lift loads or drag loads on an incline.**

**Do not use more than one winch to move a load unless each winch was designed for a multiple winch system.**

**Do not use damaged or malfunctioning equipment. To do so could result in failure of the equipment.**

**Do not modify the equipment in any way. To do so could cause equipment failure and void the warranty.**

**Check lubrication before use.**

- 2.4.1 CONSIDER THE OPERATION. Do not begin until you are sure you can perform the entire operation without hazard.
- a WHEN OPERATING REMOTELY with only a manual band brake, an operator must be present at winch for manual operation of band brake.
- 2.4.2 A PRE-OPERATION MEETING attended by the winch operator, ground crew, signal person and the person in charge of the task to be performed shall be held to plan and review the procedure to be followed, including:
- Signals.
  - Appropriate number of signal persons and ground crew.
  - Designate responsibility.
- a THIS MEETING SHALL BE HELD prior to the beginning of operations at each new work location and thereafter for any new employees assigned to the operation.
  - b DURING THIS MEETING it is recommended that a comprehensive plan to cover emergency procedures be worked out prior to exercising the winch capabilities.

- 2.4.3 INSPECT ALL COMPONENTS of the system.
- a INSPECT THE WINCH and other equipment according to Section 3.3.3 - Instructions for Frequent Inspection.
  - b OPERATORS shall be physically competent and have no health condition which might affect their ability to act, and they must have good hearing. Operators who are fatigued or have exceeded their normal shift period shall check all related regulations regarding approved work periods prior to operation. Refer to training program. The operator must thoroughly understand proper methods of rigging and attaching loads and should have a good attitude regarding safety.
  - c THE LOAD must be clear of other objects and free to move. Make sure the load will not tip, spin, roll away, or in any way move uncontrollably.
- 2.4.4 KNOW YOUR LOAD and make sure you do not exceed the load rating of the winch or any other equipment in the system.

**Figure 8 – Motor and Valve**

NOTE: Thern recommends installing mufflers in exhaust ports to reduce noise. For operation without mufflers, remove port caps from exhaust ports. In both cases it is recommended that operators use hearing protection.

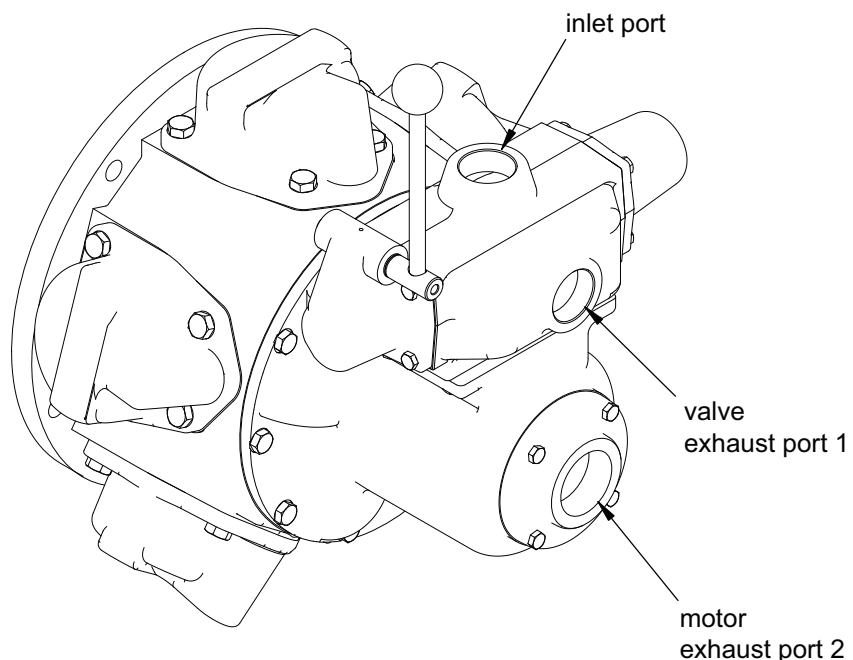



## 2.5 Attaching the Load

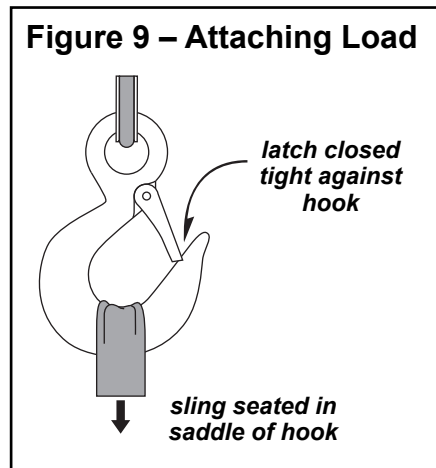

**⚠WARNING**

**Do not wrap the wire rope around the load. This damages the wire rope and could cause the load to escape. Use a sling or other approved lifting device.**

- 2.5.1 CLEAR OBJECTS from the path of the load so you can move it freely and observe it at all times during the operation.
- 2.5.2 ATTACH THE LOAD using a nylon sling, or other approved lifting device. Follow the recommendations of the sling manufacturer.
  - a SEAT THE SLING in the saddle of the hook with the hook latch completely closed. See Figure 9. Always make sure the load is properly seated in the saddle of the hook. Do not tiplload the hook as this may allow the load to slip out of engagement and leads to spreading and eventual failure of the hook.
  - b CENTER THE LOAD on the hook so it will remain balanced and not tip or rotate to one side.

## 2.6 Moving the Load

### Important!

- Obey a stop signal from anyone.
- Maintain tension on the wire rope to keep it tightly and evenly wound on the drum.
- If the winch and load are not visible during the entire operation, get help from another person.
- Appoint a supervisor if more than one person is involved in the operation. This will reduce confusion and increase safety.
- When lifting a load, use a tag line to keep the load from swinging or twisting, while keeping yourself away from the load.
- Lifting and lowering speeds shall be operator-controlled and be as slow as practical.
- The winch operator(s) shall remain at the controls at all times.

### ⚠WARNING

**Keep at least 5 wraps of wire rope wound on the drum at all times, to serve as anchor wraps. With less than 5 wraps on the drum the wire rope could come loose, causing the load to escape.**

**Keep all unnecessary personnel away from the winch. Keep out of the path of the load, and out of the path of a broken wire rope that might snap back and cause injury.**

**Keep hands away from the drum, gears, wire rope, and other moving parts of the equipment.**

**Winches must use controls that spring return to neutral and stop all motion when released. Various controls are available with the winches and are dependent on air supply, location to winch and degree of control required.**

**Operator(s) must maintain visual or audio contact with personnel and the load at all times. Operator(s) must remain at the controls at all times.**

**Monitor surrounding conditions to prevent the load from contacting hazardous obstructions.**

**Use spotters or signal person to assist with positioning the load in confined or limited visibility areas.**

**Do not divert your attention from the operation. Stay alert to the possibility of accidents, and try to prevent them from happening.**

**Do not jerk or swing the load. Avoid shock loads by starting and stopping the load smoothly. Shock loads overload the equipment and may cause damage.**

**Do not leave a suspended load unattended unless specific precautions have been taken to secure the load and keep people away from the winch and out from under the load.**

**Figure 10 – Control Valve**

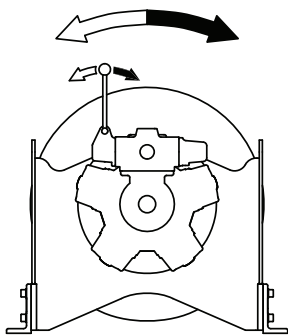

- 2.6.1 **MOVE THE LOAD** slowly and smoothly, only a small distance at first. Make sure the load is balanced and securely attached before continuing.

#### **Before operating, the following conditions shall exist:**

- WIRE ROPE shall be free of kinks.
  - MULTIPLE PART LINES shall not be twisted around each other.
  - THE PRIMARY POINT of wire rope attachment shall be centered over the load so that the load will not tilt and remain level.
  - IF THERE IS SLACK wire rope condition, the hoisting mechanisms shall be inspected to ensure all wire ropes are properly seated on drums and in sheaves, before resuming winch operation.
- 2.6.2 **USE THE CONTROL DEVICE** to operate the winch. The control device must be momentarily type, so the winch will stop when the operator releases the control. See Figure 10.
- 2.6.3 **THE MANUAL BAND BRAKE** is engaged by pushing down on the handle and disengaged by pulling up. If the handle is pushed down fully and motor control is released or in the neutral position, it should lock in that position and prevent drum rotation, until disengaged by the operator. The brake must be kept properly adjusted to hold the required load. See Figures 11.

**Figure 11 – Manual Band Brake**

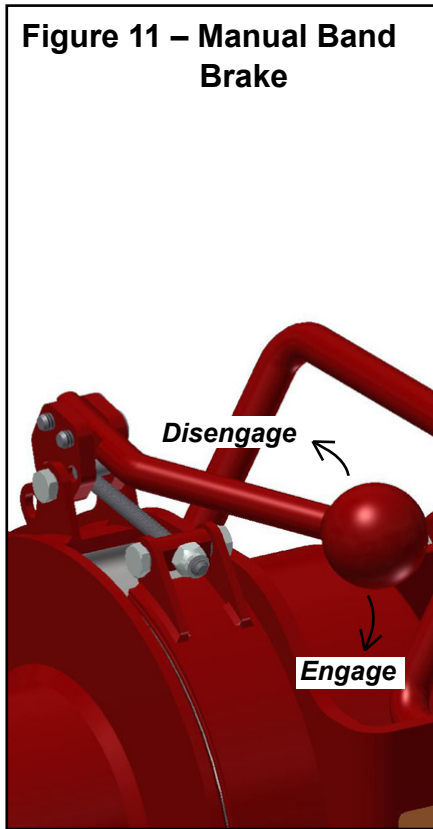

- 2.6.4 OBSERVE THE WIRE ROPE as it winds onto the drum. If it becomes loose, uneven, or overlapped, stop the operation and rewind the wire rope before continuing. Continued operation with overlapped or uneven wire rope can damage the wire rope and shorten its life.
- 2.6.5 OBSERVE THE REDUCER, MOTOR AND BRAKE during operation for signs of overheating. Frequent overheating may be a sign of damage, or may indicate the need for a larger power winch.
- a WATCH FOR SMOKE, the smell of burnt lubricant, and other signs of overheating. Use a thermocouple or other device to monitor reducer temperature.
  - b STOP THE OPERATION if the reducer, motor or brake overheats, and allow the winch to cool. Continued operation may cause damage.
  - c WHEN PAYING OUT observe the motor for overspeeding. If oversped, it may eject oil from the motor, shortening the life of the motor.
- 2.6.6 IN CASE OF AIR SUPPLY FAILURE, shut off the air supply line valve, relieve the air line pressure and DISCONNECT the air supply line from the winch. Leave the air supply DISCONNECTED. See section 2.7 - Emergency Operation.

---

## 2.7 Emergency Operation

**⚠WARNING**

**Emergency lowering operations must be performed by a minimum of two personnel trained in the operation of the winch.**

**Communication must be established between personnel and the winch operator. The operator should be able to visually monitor the load through its full range of travel.**

2.7.1 EMERGENCY OPERATION PROCEDURE for air winch with manual band brake and a suspended load can be accomplished one of two ways:

a USING AN ALTERNATIVE AIR SUPPLY

- Engage the manual band brake to hold the load. Do not let go of the band brake handle during emergency operation of winch. The manual band brake is engaged by pushing down the handle and disengaged by pulling up.
- In case of air supply failure, put the control in neutral and disconnect the air supply. Leave the primary air supply disconnected during emergency operation.
- Have a second person connect a secondary source of air to the inlet port of the control valve.
- Taking care, operate the manual band brake and control valve to lower the load.
- Remove the load from the load line.

c EMERGENCY LOWERING WITHOUT BACKUP AIR SUPPLY:

- Engage manual band brake to hold the load. DO NOT let go of the band brake handle during emergency operation of the winch. The manual band brake is engaged by pushing down the handle and disengaged by pulling up.
- Set control valve to neutral position.
- Disconnect air supply and leave disconnected during emergency operation.
- Open the control valve to the payout position and gradually disengage the band brake to slowly lower the load.

ANY QUESTIONS ON OPERATION OR WINCH APPLICATION CALL  
THERN, INC.

### 3.1 Cleaning the Winch

Clean the winch to remove dirt and help prevent rust and corrosion.

- 3.1.1 CLEAN THE WINCH every six months or whenever it is dirty. Wipe down all equipment to remove dirt and grease.
- 3.1.2 REMOVE ALL UNNECESSARY OBJECTS from the area around the winch.

### 3.2 Lubricating the Winch

#### ⚠CAUTION

**Make sure the breather plugs are clean and open to vent heat and pressure. Poor ventilation will cause overheating and result in damage to oil seals and other equipment.**

**Fill the motor and MTA1-S reducer to the proper level without overfilling. Too much or too little lubricant will cause overheating and result in damage to equipment.**

For shipment, the winch motor and reducer are filled with lubricant, and the motor breather and reducer breather plug(s) are installed.

MTA.5-S reducers are grease packed and sealed. This reducer does not require oil fill or breather plugs.

#### Important!

- Do not leave plug holes in the reducer or motor open. Open plug holes will allow dirt and moisture to contaminate the lubrication.
- Make sure lubricant has a temperature rating appropriate for the ambient temperatures of the operation.
- Lubricate the winch properly to help protect it from wear and rust. Read the following instructions carefully.

- 3.2.1 LUBRICATE THE MOTOR AND REDUCER according to the manufacturer's instructions.
  - a FILL THE MOTOR AND MTA1-S REDUCER with oil before operating the winch. Fill the reducer and motor until oil reaches the level check plug. **Do not mix different lubricants.** See Table 1.
  - b CHECK OIL LEVEL before every operation and every 10 hours during operation. Remove the level plug and make sure oil is even with the plug hole. See Figure 12.
  - c CHANGE MOTOR AND MTA1-S REDUCER LUBRICANT at least every 2 years, or whenever it is dirty or contaminated. See Figure 12.
- 3.2.2 LUBRICATE THE WIRE ROPE by following the wire rope manufacturer's recommendations.
- 3.2.3 IF WINCH IS DISASSEMBLED, clean all parts thoroughly and coat bearings and seals with clean grease. Use sufficient grease to provide a good protective coat.
- 3.2.4 OIL DRAIN/FILL PROCESS. See Figure 12.

**Figure 12 - MTA Series**

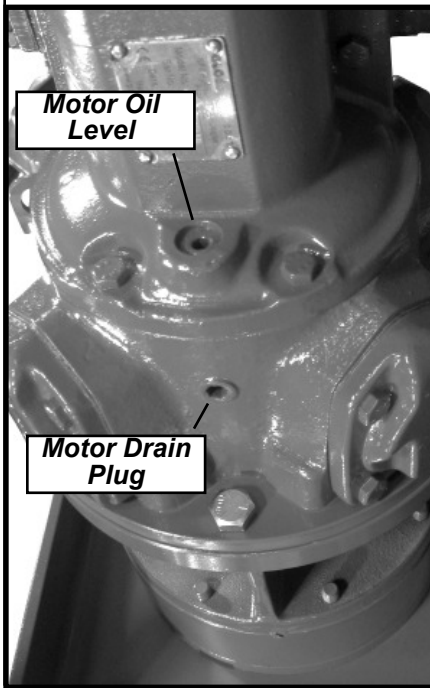

- a MTA1-S REDUCER
  1. Remove oil drain plug at bottom of reducer.
  2. Remove breather plug from top of reducer. See Figure 3B.
  3. Allow all oil to drain.
  4. Replace oil drain plug.
  5. Fill oil at breather location until the indicator reads full.
  6. Replace breather plug back on top of reducer.
- b MOTOR
  1. Remove oil drain plug at bottom of motor.
  2. Remove breather plug at top of motor.
  3. Allow all oil to drain.
  4. Replace oil drain plug.
  5. Remove oil level plug.
  6. Fill oil until level with oil level plug hole.
  7. Replace level plug and breather plug.

**Table 2 - Approved Grease Table**

Ambient Temperature <sup>1</sup>		Exxon Grease
°F	°C	
-4 to 14	-20 to -10	Beacon 325
14 to 122	-10 to 50	Unirex N2 Grease (NLGI Grade #2)

MTA.5-S reducers ship with Unirex N2 grease. This information is provided for maintenance purposes.

**Table 1 - Approved Oil Table**

Ambient Temperature <sup>1</sup>		Chevron/ Texaco Oil	Exxon Oil	Mobil Oil	Shell Oil	BP Oil
°F	°C					
-4 to 14°	-20 to -10°				Tellus T15	
14 to 41°	-10 to 5°	EP Gear Compound 68	Spartan EP 68	Mobilgear 600 XP 68 (ISO VG 68)	Omala S2 G 68	Energol GR-XP 68
32 to 95°	0 to 35°	EP Gear Compound 100, 150	Spartan EP 100, EP 150	Mobilgear 600 XP 100, 150 (ISO VG 100, 150)	Omala S2 G 100, 150	Energol GR-XP 100, GR-XP 150
86 to 122°	30 to 50°	EP Gear Compound 220, 320, 460	Spartan EP 220, EP 320, EP 460	Mobilgear 600 XP 220, 320, 460 (ISO CG 220, 460)	Omala S2 G 220, 320, 460	Energol GR-XP 220, GR-XP 320, GR-XP 460

MTA.5-S motor will ship with 3 ounces of oil. MTA1-S motor will ship with 11 ounces.

MTA1-S reducer requires no more than 12 ounces of oil.

MTA1-S reducer will ship with 600XP220.

<sup>1</sup> For operation in temperatures colder than those listed here, please contact the factory for suggested lubricants.

## 3.3 Inspecting the Equipment

### Important!

- Start an inspection program as soon as you put the winch into use.
- Appoint a qualified person to be responsible for regularly inspecting the equipment.
- Keep written records of inspection. This allows comparison with comments from previous inspections so you can see changes in condition or performance.
- Make sure all labels and plates are readable, firmly attached, free of damage and clean. Replacements are available from the factory.

### Important!

Increase the frequency of maintenance procedures if the winch is:

- Operated for long periods.
- Used to pull heavy loads.
- Operated in wet, dirty, hot or cold surroundings.

### **⚠WARNING**

**Do not use damaged or malfunctioning equipment. Place an “OUT OF ORDER” sign on the winch. Do not use the winch until the sign is removed by a qualified maintenance person who has completely corrected the problem.**

Inspect the winch to detect signs of damage or poor operation before they become hazardous. See Table 3 - Inspection Checklist.

3.3.1 CONSULT APPLICABLE CODES AND REGULATIONS for specific rules on inspecting the winch and other equipment.

3.3.2 CHECK COMPONENT MANUFACTURER’S INSTRUCTIONS for inspecting the motor, brake, reducer, bearings, wire rope, and other equipment.

### 3.3.3 Instructions for Frequent Inspection

- a VISUALLY INSPECT the entire winch and all other equipment involved in the operation.
- Check all equipment for cracks, dents, bending, rust, wear, corrosion and other damage.
  - Make sure the wire rope is installed correctly and anchored securely to the drum.
  - Check the reducer and motor for signs of leakage.
  - Make sure the entire winch is properly lubricated.
  - Make sure the motor and MTA1-S reducer breather plugs are clean, open, and installed correctly. The MTA.5-S uses a sealed reducer with no plug.
  - Make sure mounting fasteners are tightened securely.
  - Make sure the foundation is in good condition, and capable of supporting the winch and its load under all load conditions.
  - Check air supply and connections for wear, corrosion, cuts, and other damage.
- b TEST WINCH PERFORMANCE by operating the winch with a load not exceeding the load rating.
- Listen for unusual noises, and look for signs of damage as you operate the winch.
  - Make sure the wire rope winds evenly and tightly onto the drum. If it is loose or uneven, rewind it before continuing.
  - Make sure the load moves smoothly, without hesitation or strain.
  - Make sure the winch responds to the control device. It must rotate as shown on the control labels, and it must turn off when you release the control.
  - Check the brake. Raise the load, then lower it and stop it a few feet off the ground. If the load continues to coast or creep under normal operating conditions, the brake needs adjustment. See Section 2.2 - Inspecting/ Adjusting the Brakes.

**Completely correct all problems before continuing. Use the Troubleshooting Chart to help determine the cause of certain problems. See Table 4.**

3.3.4 **Instructions for Periodic Inspection, See Table 3.**

- a VISUALLY INSPECT the winch and all other equipment.
- Disassembly may be required in order to properly inspect individual components. Contact factory for assembly/disassembly instructions. Disassembly before contacting Thern, Inc. voids all warranties.
  - Check the finish for wear, flaking, or other damage.
  - Check all equipment for cracks, dents, bending, rust, wear, corrosion and other damage. If the equipment was overloaded, or if you notice cracks and other signs of overloading and damage, promptly remove equipment from use and have it repaired or replaced. **DO NOT CONTINUE TO USE DAMAGED OR OVERLOADED EQUIPMENT OR WIRE ROPE.**
  - Check all fasteners for stripped threads, wear, bends, and other damage.
  - Check the reducer and motor for signs of leakage.
  - Make sure the motor and MTA1-S reducer breather plug is clean, open and installed correctly.
  - Make sure all labels and plates are readable, firmly attached, free of damage and clean. Replacements are available from the factory.
- b DRAIN A SMALL AMOUNT OF LUBRICANT from the motor and MTA1-S reducer into a clean container.
- Check the lubricant for dirt, metal particles, water, and other signs of contamination. Completely drain the reducer and motor if lubricant is contaminated.
  - Make sure the winch is completely lubricated. See section 3.2 - Lubricating the winch.
- c INSPECT THE WIRE ROPE according to the wire rope manufacturer's recommendations, or follow accepted industry standards for wire rope inspection.
- Always wear protective clothing when handling wire rope.
  - Check the entire length of wire rope for bent wires, crushed areas, broken or cut wires, corrosion, and other damage. Carefully inspect areas that pass over sheaves or through roller guides.
  - Note the location and concentration of broken wires. Replace wire rope if more than 6 wires are broken in one lay, or more than 3 wires are broken in one strand in one lay. See Figure 14.
  - Make sure the load hook or other device is securely attached to the wire rope, and the wire rope where it is attached is not frayed, corroded, broken, or otherwise damaged.
  - Measure the throat opening, thickness, and twist of the hook. Replace the hook if it shows signs of damage. See Figure 16.
  - Make sure hook latch opens without binding and closes when released.
  - Check the anchor holes in the drum and the surrounding area for signs of wear or distortion.

**Frequent Wire Rope Inspection:**

- Use ASME B30.7 as a guideline for rope inspection, replacement and maintenance.
- Check the wire rope, end connections and end fittings for corrosion, kinking, bending, crushing, birdcaging or other signs of damage.
- Check the number, distribution and type of visible broken wires. See paragraph 3.3.4 c and Figure 14.
- Check the wire rope for reduction of rope diameter from loss of core support, or wear of outside wires. See Figure 15.
- Take extra care when inspecting sections of rapid deterioration such as sections in contact with saddles, sheaves, repetitive pickup points, crossover points and end connections.



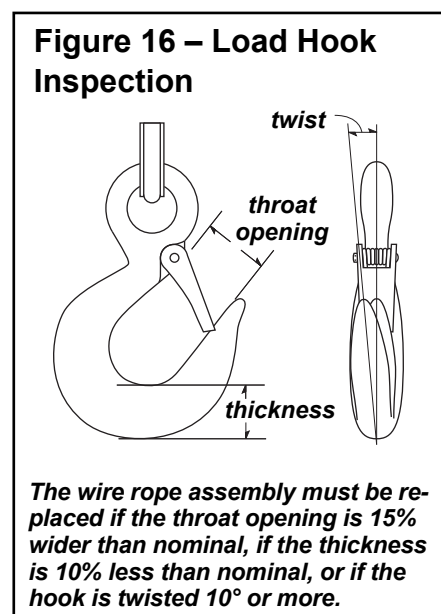
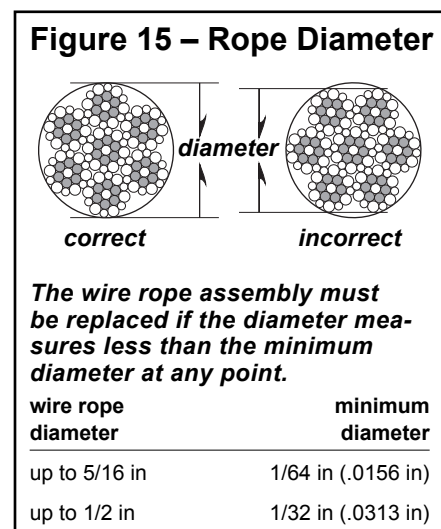
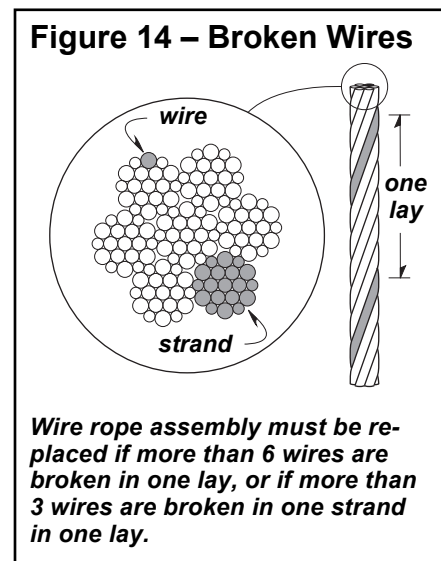

- d MOVE THE DRUM with your hands. Check for excessive movement indicating worn or loose gears or bearings. Excessive movement is caused by overloading or overheating, and is a sign that your application may require a larger power winch. Disassemble the winch if necessary. Inspect gears, keys, bearings, seals, and shafts for wear, distortion, and other damage.
- e PLACE enough weight to keep the wire rope straight and tightly drawn.
  - Measure the diameter of the wire rope, especially in areas where wear is noticeable. Replace the wire rope if the diameter measures below the minimum diameter at any point. See Figure 15.
- f INSPECT THE FOUNDATION AND RIGGING.
  - Check mounting fasteners for stripped threads, wear, and other damage.
  - Check the foundation for cracks, corrosion, and other damage.
- g TEST WINCH PERFORMANCE by operating the winch with a load equal to the load rating.
  - Listen for unusual noises, and look for signs of damage as you operate the winch.
  - Make sure the wire rope winds evenly and tightly onto the drum. If it is loose or uneven, rewind it before continuing.
  - Observe the rotating drum, look for signs of loose or misaligned bearings.
  - Make sure the winch responds to the control device. It must rotate as shown on the control labels, and it must turn off when you release the control.
  - Make sure the load moves smoothly without hesitation or strain.
  - Check the brake. Raise the load, then lower it and stop it a few feet off the ground. If the load continues to coast or creep under normal operating conditions, the brake needs adjustment. See Section 2.2 - Inspecting/ Adjusting the Brakes.
- h DISCONNECT AIR SUPPLY and inspect equipment.
  - Check air supply and connections for wear, corrosion, cuts and other damage.
- i CONNECT AIR SUPPLY.

**Completely correct all problems before continuing. Use the troubleshooting chart to help determine the cause of certain problems. See Table 4.**

**Table 3 – Inspection Checklist**

*checked boxes indicate damage or problem in need of repair*

	<b>damages</b>	<b>problems</b>
<b>general</b>	<input type="checkbox"/> finish weathered, flaking, otherwise damaged <input type="checkbox"/> parts cracked, bent, rusted, worn, otherwise damaged	<input type="checkbox"/> winch jerks or hesitates during operation <input type="checkbox"/> unusual noises, other signs of malfunction
<b>fasteners</b>	<input type="checkbox"/> stripped threads, bent, worn, otherwise damaged	<input type="checkbox"/> loose, not tightened to proper torque
<b>reducer</b>	<input type="checkbox"/> gears, bearings, or shafts loose, worn, otherwise damaged <input type="checkbox"/> lubricant leakage	<input type="checkbox"/> not properly lubricated <input type="checkbox"/> lubricant contaminated
<b>wire rope</b>	<input type="checkbox"/> bent, crushed, otherwise damaged <input type="checkbox"/> broken wires, see Figure 14 replace if more than 6 wires in one lay, or 3 wires in one strand in one lay, are broken <input type="checkbox"/> diameter reduced, see Figure 15 replace if diameter is excessively worn	<input type="checkbox"/> wire rope loosely or unevenly wound  number per strand = _____ number per lay = _____  diameter = _____
<b>end connections</b>	<input type="checkbox"/> corroded, rusted, worn, otherwise damaged	<input type="checkbox"/> not securely attached
<b>hook or other device</b>	<input type="checkbox"/> twisted, bent, worn, otherwise damaged, see Figure 16 replace if twist is 10 degrees or more replace if throat width is 15% larger than nominal replace if thickness is 10% less than nominal	<input type="checkbox"/> hook latch fails to close when released twist = _____ throat width = _____ thickness = _____
<b>drum</b>	<input type="checkbox"/> anchor worn, distorted, otherwise damaged	<input type="checkbox"/> excessive movement or backlash
<b>motor</b>	<input type="checkbox"/> motor corroded, worn out, otherwise damaged	<input type="checkbox"/> motor is sluggish, or operates poorly
<b>brake</b>	<input type="checkbox"/> brake worn, corroded, otherwise damaged	<input type="checkbox"/> brake does not operate properly
<b>control device</b>	<input type="checkbox"/> control components corroded, worn out, otherwise damaged	<input type="checkbox"/> fails to control winch properly
<b>air supply</b>	<input type="checkbox"/> air lines cracked, cut, corroded, otherwise damaged <input type="checkbox"/> connections loose, corroded, otherwise damaged	<input type="checkbox"/> wires unprotected, obstructing traffic pressure at motor = _____
<b>labels and plates</b>	<input type="checkbox"/> dirty, illegible, otherwise damaged	<input type="checkbox"/> loosely attached or missing

**comments**

\_\_\_\_\_

\_\_\_\_\_

\_\_\_\_\_

\_\_\_\_\_

\_\_\_\_\_

\_\_\_\_\_

\_\_\_\_\_

\_\_\_\_\_

\_\_\_\_\_

\_\_\_\_\_

\_\_\_\_\_

\_\_\_\_\_

\_\_\_\_\_

\_\_\_\_\_

\_\_\_\_\_

\_\_\_\_\_

\_\_\_\_\_

\_\_\_\_\_

\_\_\_\_\_

\_\_\_\_\_

\_\_\_\_\_

\_\_\_\_\_

\_\_\_\_\_

**authorized signature** \_\_\_\_\_ **date** \_\_\_\_\_

### Table 4 – Troubleshooting Chart

Contact the factory for assembly/disassembly instructions. Disassembly before contacting Thern, Inc. voids all warranties.

problem	cause	correction
<b>motor won't run</b>	<ul style="list-style-type: none"> <li>• no air supply to winch . . . . .</li> <li>• load too heavy. . . . .</li> <li>• motor damaged. . . . .</li> </ul>	<ul style="list-style-type: none"> <li>.check air supply line connections and hoses</li> <li>.lighten load</li> <li>.repair or replace as necessary</li> </ul>
<b>winch runs slow</b>	<ul style="list-style-type: none"> <li>• improper hose or fitting size</li> <li>• load too heavy . . . . .</li> <li>• motor may be damaged . . . . .</li> <li>• bearing seized up . . . . .</li> <li>• exhaust ports restricted. . . . .</li> </ul>	<ul style="list-style-type: none"> <li>check fittings, connections for size and length. Replace parts that may restrict air flow. Inspect air line filter. Make sure both exhaust ports are not restricted.</li> <li>.lighten load</li> <li>.inspect and replace as necessary</li> <li>.inspect and replace as necessary</li> <li>.remove cap and install mufflers</li> </ul>
<b>motor runs, drum doesn't turn</b>	<ul style="list-style-type: none"> <li>• loose or broken gear keys or splines . . . . .</li> <li>• loose, stripped or broken gears . . . . .</li> </ul>	<ul style="list-style-type: none"> <li>.inspect and replace as necessary</li> <li>.inspect and replace as necessary</li> </ul>
<b>motor tries to turn but can't</b>	<ul style="list-style-type: none"> <li>• unit overheated . . . . .</li> <li>• load too heavy. . . . .</li> <li>• motor may be damaged . . . . .</li> <li>• insufficient air supply. . . . .</li> <li>• brake may not be released . . . . .</li> <li>• gears or bearings broken or locked . . . . .</li> </ul>	<ul style="list-style-type: none"> <li>.allow to cool</li> <li>.lighten load</li> <li>.inspect and repair as necessary</li> <li>.verify air supply pressure and volume at winch inlet meet the requirements listed</li> <li>.inspect and repair as necessary</li> <li>.inspect and replace as necessary</li> </ul>
<b>air lines freeze</b>	<ul style="list-style-type: none"> <li>• water in air supply</li> </ul>	<ul style="list-style-type: none"> <li>install or drain air system moisture traps, moisture collecting air receivers and compressor aftercoolers. After corrective actions have been taken, disconnect lines at winch inlet and purge with clean, dry air or nitrogen prior to attaching load and operating winch.</li> </ul>
<b>brake does not operate properly</b>	<ul style="list-style-type: none"> <li>• brake release lever in release position . . . . .</li> <li>• brake adjusted incorrectly . . . . .</li> <li>• brake worn or damaged . . . . .</li> <li>• brake components seized up or damaged . . . . .</li> <li>• load too heavy. . . . .</li> </ul>	<ul style="list-style-type: none"> <li>.move to lock position</li> <li>.inspect and adjust brake</li> <li>.inspect and replace as necessary</li> <li>.inspect and repair as necessary</li> <li>.lighten load</li> </ul>
<b>lubricant leakage</b>	<ul style="list-style-type: none"> <li>• worn bearings . . . . .</li> <li>• damaged oil seals or gaskets . . . . .</li> <li>• cracked or damaged reducer or motor . . . . .</li> </ul>	<ul style="list-style-type: none"> <li>.inspect and replace as necessary</li> <li>.inspect and replace as necessary</li> <li>.inspect and repair as necessary</li> </ul>
<b>excessive end play on drive shaft</b>	<ul style="list-style-type: none"> <li>• loose or damaged keys, keyways or splines. . . . .</li> <li>• excessively worn gears . . . . .</li> </ul>	<ul style="list-style-type: none"> <li>.inspect and replace as necessary</li> <li>.inspect and repair as necessary</li> </ul>
<b>excessively worn gears or bearings</b>	<ul style="list-style-type: none"> <li>• load too heavy. . . . .</li> <li>• poor lubrication of reducer or bearings . . . . .</li> </ul>	<ul style="list-style-type: none"> <li>.lighten load</li> <li>.inspect and lubricate as necessary</li> </ul>

**Table 4 – Troubleshooting Chart (continued)**

Contact the factory for assembly/disassembly instructions. Disassembly before contacting Thern, Inc. voids all warranties.

<b>problem</b>	<b>cause</b>	<b>correction</b>
<b>overheating</b>	• operated too long without rest . . . . .	allow to cool
	• load too heavy . . . . .	lighten load
	• poor lubrication . . . . .	inspect and lubricate as necessary
	• breather plug clogged or damaged . . . . .	clean or replace vent plug as needed
	• bearing seized up . . . . .	inspect and replace as necessary
	• low oil level in motor or MTA1-S reducer . . . . .	check oil levels and add or drain as necessary
	• contaminated lubrication . . . . .	drain, clean and lubricate as necessary
<b>unusual noises</b>		
high pitched squeak	• poor lubrication . . . . .	inspect and lubricate as necessary
grinding noise	• contaminated lubrication . . . . .	drain, clean and lubricate the winch
	• broken gears or bearings . . . . .	inspect and replace as necessary
knocking motor	• load too heavy . . . . .	lighten load
	• motor overheated . . . . .	allow to cool
	• damaged motor . . . . .	inspect and replace as necessary
rattling noise	• loose fasteners or set screws . . . . .	tighten all fasteners and screws
	• worn or loose band brake . . . . .	inspect and repair or tighten as necessary
heavy thump during operation	• contaminants in lubricant . . . . .	drain, clean and lubricate the winch
	• loose set screws or keys in gears or shafts . . . . .	inspect and repair as necessary
	• bearings defective . . . . .	inspect and replace as necessary

**comments**

\_\_\_\_\_

\_\_\_\_\_

\_\_\_\_\_

\_\_\_\_\_

\_\_\_\_\_

\_\_\_\_\_

\_\_\_\_\_

\_\_\_\_\_

\_\_\_\_\_

\_\_\_\_\_

\_\_\_\_\_

\_\_\_\_\_

\_\_\_\_\_

\_\_\_\_\_

\_\_\_\_\_

\_\_\_\_\_

\_\_\_\_\_

\_\_\_\_\_

\_\_\_\_\_

\_\_\_\_\_

\_\_\_\_\_

\_\_\_\_\_

authorized signature \_\_\_\_\_ date \_\_\_\_\_

---

## 3.4 Repairing the Winch

**Important!**

- It is your responsibility to determine when to replace parts. When considering whether to continue using a part or to replace it, remember that replacing it is the best way to avoid further equipment damage.
- Replace spring pins, retaining rings, and oil seals whenever the winch is disassembled for inspection or repair.
- Appoint a qualified person to be responsible for all repairs to the equipment.
- Turn off air system and depressurize air lines before performing any maintenance.

- 3.4.1 GET FACTORY AUTHORIZATION for all repairs. Unauthorized repairs will void the warranty, and may lead to damage or failure of the winch.
- 3.4.2 REPLACE DAMAGED OR POORLY OPERATING PARTS with Thern repair parts.
- 3.4.3 CLEAN THE DRUM BRAKE BAND using a wire brush or emery cloth. Do not wash the drum brake band in liquid. If the drum brake band lining is oil soaked, it must be replaced.
  - a INSPECT THE DRUM BAND BRAKE LINING for oil, grease and glazing. If the drum band brake lining is oil-soaked replace the brake bands as a set. Remove glazed areas of band brake lining by sanding lightly with a fine grit emery cloth.
  - b MEASURE THE THICKNESS OF THE DRUM BAND BRAKE LINING. If the drum brake band linings are less than .015 inch thick anywhere along the edges replace the brake bands as a set.
- 3.4.4 REFINISH AREAS where the paint is worn or flaking. A good finish helps to protect against corrosion and weather damage.
  - a REMOVE THE FINISH from damaged areas, down to the bare metal.
  - b CLEAN THE AREA thoroughly.
  - c REPAINT with a high quality primer and finishing coat.
- 3.4.5 TO ORDER REPAIR PARTS, contact your local dealer. Include the following information when ordering:
  - model number (**See Figure 1**)
  - **serial number** (or code number) (**See Figure 1**)
  - part number
  - date purchased, and from whom
  - description of what happened, or what is wrong
  - your name and return address

---

## 4.1 Transporting the Winch

**Important!**

- Keep a record of what you ship and when you send it.

- 4.1.1 REMOVE THE BREATHER PLUG and install a sealed plug to prevent the loss of lubrication during shipment.
- 4.1.2 PACK THE WINCH in an upright position for transport, using the original packaging materials, if possible.
  - a FASTEN THE WINCH to a wooden base using bolts, to keep it from moving during transport.
  - b SEAL THE WINCH in plastic with a desiccant to help protect it from rust, corrosion, and other damage.
  - c CONSTRUCT WOODEN SIDES and top to enclose the winch in a solid protective crate.
  - d PACK LOOSE PARTS in small boxes or ship separately.
- 4.1.3 INSPECT THE WINCH according to the Instructions for Periodic Inspection before installing it in a new location.

---

## 4.2 Storing the Winch

- 4.2.1 FILL THE MOTOR AND MTA1-S REDUCER with lubricant, and make sure the breather plugs are clean and properly installed. Add a rust preventative for long term storage. Follow the reducer and motor manufacturer's instructions.
- 4.2.2 SEAL THE WINCH in plastic with a desiccant to help protect it from rust, corrosion, and other damage.
- 4.2.3 STORE THE WINCH upright, in a cool clean place away from corrosive chemicals and moisture.
- 4.2.4 ROTATE THE DRUM PERIODICALLY to keep bearing and gears surfaces from becoming lacquered. Release the brake to rotate the drum.
- 4.2.5 INSPECT THE WINCH according to the Instructions for Periodic Inspection before installing it for operation. See Section 3.3.4.
- 4.2.6 DRAIN THE MOTOR AND MTA1-S REDUCER and fill with proper lubricant prior to operation.

**This page intentionally left blank.**

MTA Performance Characteristics\*\*\*\*

	MTA.5-S Series		MTA1-S Series	
	Standard	Metric	Standard	Metric
Load Rating 1st Layer	1,400 lb	635 kg	2,700 lb	1,224 kg
Load Rating Mid-Drum	1,000 lb	453 kg	2,000 lb	907 kg
Load Rating Full Drum	800 lb	362 kg	1,600 lb	725 kg
Line Speed 1st Layer *	30 fpm	9.1 m/min	40 fpm	12.2m/min
Line Speed Mid-Drum *	41 fpm	12.5 m/min	54 fpm	16.5 m/min
Line Speed Full Drum *	52 fpm	15.6 m/min	67 fpm	20.4 m/min
Input HP	1.35 hp	1.35 hp	3.5 hp	3.5 hp
Max. Stall Pull 1st Layer	2600 lb	1179.3 kg	5800 lb**	2630.8 kg**
Pressure	90 psi	6.3 kgf/cm2	90 psi	6.3 kgf/cm2
Flow	60 scfm	1.70 m3/min	140 scfm	3.96 m3/min
Pipe Inlet Size	.5 in	12.7 mm	.75 in	19.1 mm
Hose Size	.75 in	19.1 mm	1 in	25.4 mm
Min. Design Temp***	(-4°)F	(-20°)C	(-4°)F	(-20°)C

\* Line speeds vary based on conditions of air supply.

\*\* Estimated Value.

\*\*\* Use appropriate lubricant.

\*\*\*\* Note air supply condition requirements.

				Drum Capacities																			
				4.5 in (115 mm)						5 in (127 mm)						13 in (330 mm)							
		Rope Diameter		Breaking Strength		1st Layer		Mid Drum		Full Drum		1st Layer		Mid Drum		Full Drum		1st Layer		Mid Drum		Full Drum	
		(in)	(mm)	(lb)	(kg)	(ft)	(m)	(ft)	(m)	(ft)	(m)	(ft)	(m)	(ft)	(m)	(ft)	(m)	(ft)	(m)	(ft)	(m)	(ft)	(m)
MTA.5-S		0.25	6.4	7,000	3,175	16	4.9	87	36.6	190	58.0	-	-	-	-	-	-	-	-	-	-	-	-
MTA1-S		0.38	10.0	14,440	6,532	-	-	-	-	-	-	17	5.2	100	39.7	220	67.1	55	16.8	260	109.8	580	176.8

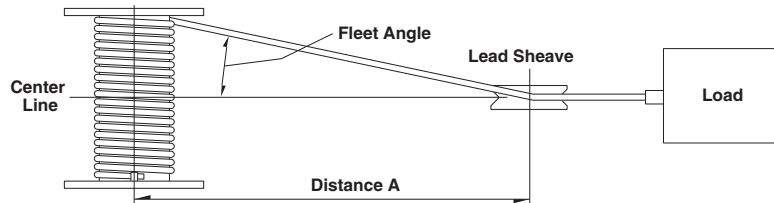

distance A in ft with a 1.5° fleet angle = (drum width in inches) x 1.59  
 with a 2° fleet angle = (drum width in inches) x 1.19

**Recommended Max. Fleet Angle**

smooth drum = 1.5°  
 grooved drum = 2°



FILTER-REGULATOR-LUBRICATOR (F-R-L) <sup>1</sup>		
model	part number	qty
MTA.5-S	B3310	1
MTA1-S	B3321	1

**F-R-L Assembly**

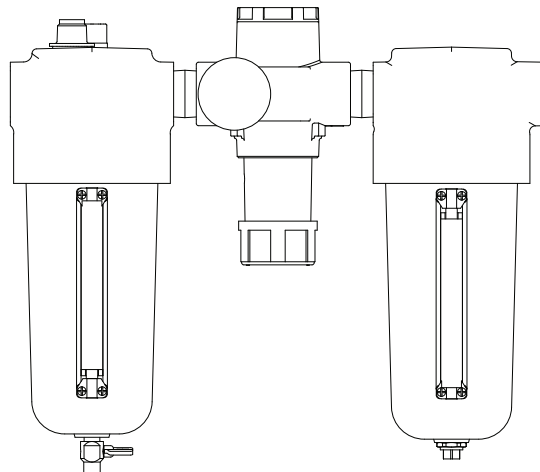

Note: Air supply must be dry enough to avoid ice formation at temperatures below 35°F (2°C)

MUFFLER ASSEMBLY			
item	description	part number	qty
MTA.5-S		B5915	
1	FITTING ELBOW .5 NPT 90 DEG GALV	A11790	1
1a	FITTING ELBOW .75NPT 90 DEG GALV	A11789	1
2	MUFFLER SHELL TYPE .5 NPT MALE	A6976	1
2a	MUFFLER SHELL TYPE .75 NPT MALE	A11788	1
MTA1-S		B6010	
1	FITTING ELBOW .75NPT 90 DEG GALV	A11789	1
1a	FITTING ELBOW 1 NPT 90 DEG GALV	A7016	1
2	MUFFLER SHELL TYPE .75 NPT MALE	A11788	1
2a	MUFFLER SHELL TYPE 1 NPT MALE	A7008	1

**Muffler Assembly**

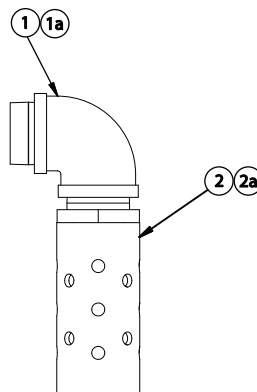

Note: Air supply must be dry enough to avoid ice formation at temperatures below 35°F (2°C)

MTA.5-S SERIES - CONTROL VALVE			
item	description	part number	qty
1	END CAP GASKET	111-066	2
2E	MATCHED SPOOL AND SLEEVE (EQUIPOWER)	111-913	1
4	SHOULDER SCREW 8 MM	817-003	1
5	CENTERING SHAFT GUIDE	111-071	1
6	HEX HEAD SCREW M6 X 16	802-016	8
8	O-RING 27, 5 X 30	808-027	6
9	VALVE BODY	111-060	1
10	VALVE SLEEVE SPACER	111-068	1
11	WASHER, SPRING CENTERING	111-072	1
12	SPRING 323714	814-016	1
13	END CAP - SPRING END	111-064	1
14	HAND LEVER CAP	113-041	1
15	HEX HEAD BOLOT M6 X 50	802-024	2
16	TOGGLE SHAFT	113-024	1
17	TOGGLE PIN	113-026	1
18	HAND LEVER PIVOT	113-008	1
19	HAND LEVER	313-002	1
20	BLACK PLASTIC KNOB 31 MM	818-002	1
21	CIRCLIP 20 MM EXTERNAL	804-013	2
22	GRUB SCREW M8 X 10	815-010	1
23	GRUB SCREW M8 X 16	815-022	1
24	PLUG 1/8" BSPT	816-063	3
26	VENT PLUG	113-050	1

**MTA.5-S Series Control Valve**

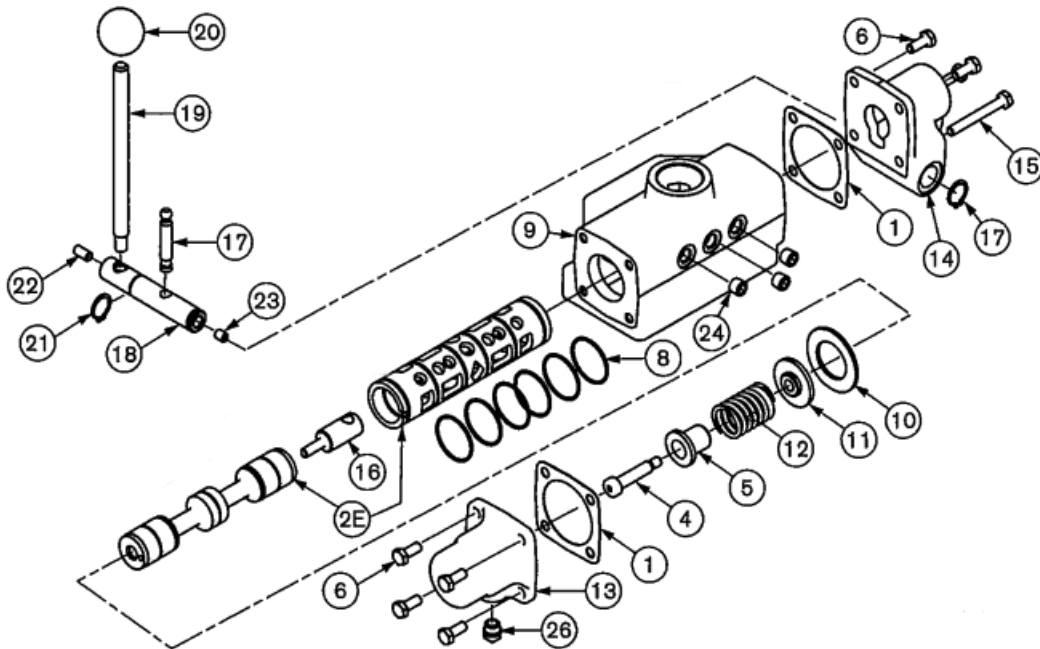

**This page intentionally left blank.**

MTA.5-S SERIES - PISTON AIR MOTOR				
item	description	part number	qty	kit no.
1	ROTARY VALVE BEARING (OUTER)	807-020	1	
2	ROTARY VALVE	130-006	1	
3	ROTARY VALVE HOUSING	130-011	1	
4	ROTARY VALVE BEARING (INNER)	807-021	1	
5	ROTARY VALVE BEARING CIRCLIP	804-051	1	
6	ROTARY VALVE HOUSING GASKET	100-001	1	139-911
7	CYLINDER GASKET	110-030	4	139-911
8	CYLINDER	110-082	4	
9	PISTON ASSEMBLY	130-902	4	
10	COMPRESSION RING	100-024	4	139-911
11	OIL CONTROL RING	100-022	4	139-911
12	KING ROD	140-077	1	
13	CRANKSHAFT SPACER	140-013	1	
14	CRANKSHAFT CIRCLIP	804-006	1	
15	CRANKSHAFT SPACER	100-035	1	
16	CRANKSHAFT SPACER SHIM	100-049	5	
18	CRANKSHAFT BEARING CIRCLIP	804-051	2	
19	CRANKSHAFT OILSEAL	808-043	1	139-911
20	STD CRANKSHAFT ASSEMBLY	110-901	1	
24	STD FLANGE PLATE	130-076	1	
25	FLANGE PLATE SEAL	808-033	1	139-911
26	PLUG	816-074	1	
27	ENGINE CASE	130-012	1	
29	QUEEN ROD PIVOT	140-081	3	
30	QUEEN ROD	140-078	3	
31	CRANK SPACER SELECT	140-052	1	
32	CRANK SPACER ON	140-053	1	
33	CRANK SPACER ASSEMBLY	140-054/055	1	
34	CRANE SPACER	140-056	1	
35	BALANCE WEIGHT	130-010	1	
36	WOODRUFF KEY	811-016	1	
37	CYLINDER BOLTS	802-020	16	
38	VALVE HOUSING BOLTS	802-020	4	
40	ADAPTER PLATE BOLT	802-020	4	
41	EXHAUST COVER BOLTS	802-016	2	
44	DIPSTICK (VERTICAL MOUNTING)	100-040	1	
45	SEAL (TRANSIT ONLY)	808-004	1	
46	BREATHER PLUG	130-066	1	
48	NEEDLE BEARING	807-042	1	
49	GRUB SCREW	815-012	1	
50	KEY	811-002	1	
51A	ROTARY VALVE EXHAUST COVER BSP	130-005	1	
51B	ROTARY VALVE EXHAUST COVER NPT	130-105	1	
52	FLANGE BOLT	810-003	8	
55	OUTPUT SHAFT BRG (OUTER)	807-007	1	
56	OUTPUT SHAFT BRG (INNER)	807-007	1	
60	OIL LEVEL PLUG	816-063	1	
72A	INLET ADAPTER PLATE BSP	130-003	1	
72B	INLET ADAPTER PLATE NPT	130-103	1	
73	INLET ADAPTOR PLATE GASKET	130-004	1	139-911
75	DIPSTICK SEAL	808-008	1	139-911
	SEAL KIT	139-911	1	

### MTA.5-S Series Motor Assembly

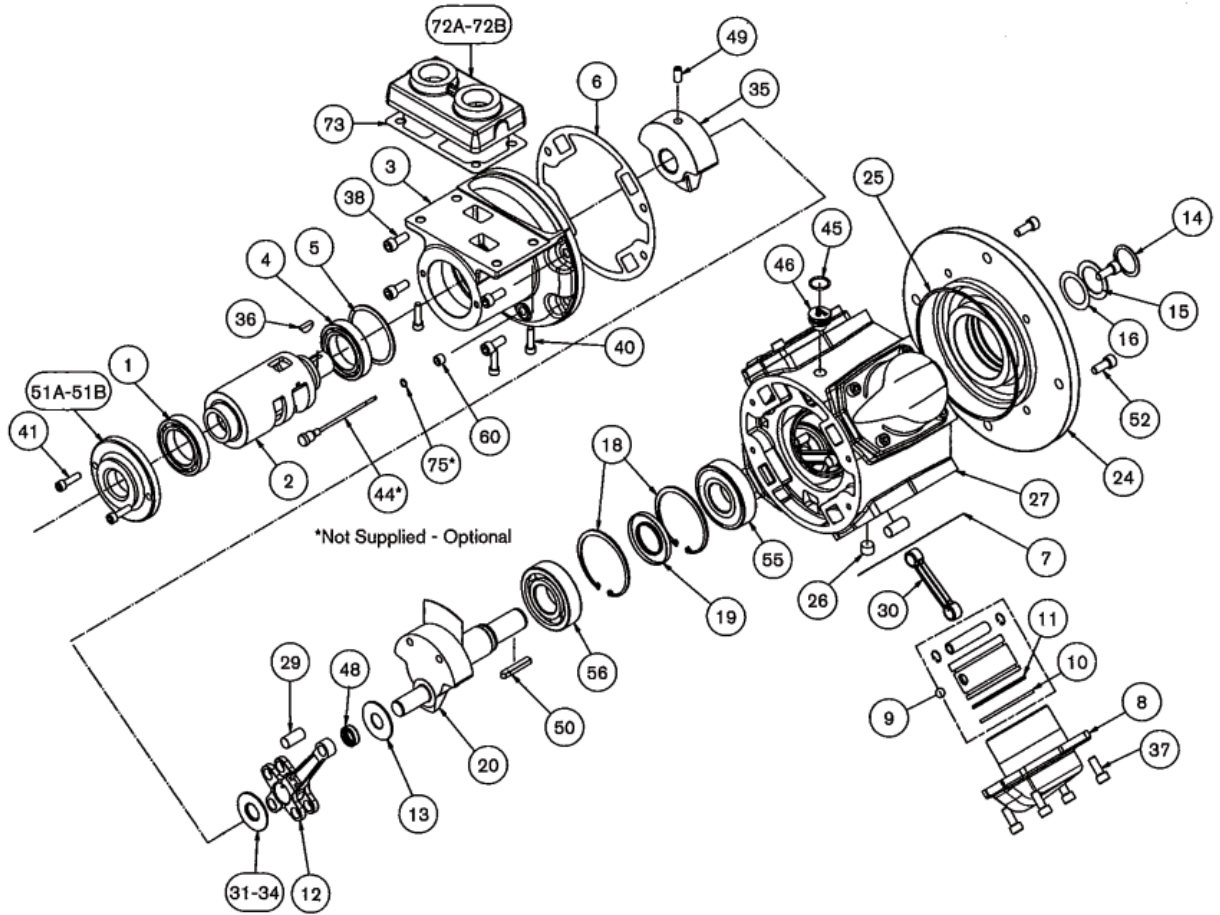

**MTA1-S SERIES - CONTROL VALVE**

item	description	part number	qty
1	END CAP GASKET	111-066	2
2E	MATCHED SPOOL AND SLEEVE (EQUIPOWER)	221-913	1
4	SHOULDER SCREW 8 MM	817-003	1
5	CENTERING SHAFT GUIDE	111-071	1
6	HEX HEAD SCREW M6 X 16	802-016	6
8	O RING 27, 5 X 30	808-027	6
9	VALVE BODY	221-060	1
10	VALVE SLEEVE SPACER	111-068	1
11	WASHER, SPRING CENTERING	111-072	1
12	SPRING 323714	814-016	1
13	END CAP - SPRING END	111-064	1
14	HAND LEVER CAP	113-041	1
15	HEX HEAD BOLT M6 X 50	802-024	2
16	TOGGLE SHAFT	113-024	1
17	TOGGLE PIN	113-026	1
18	HAND LEVER PIVOT	113-008	1
19	HAND LEVER	313-002	1
20	BLACK PLASTIC KNOB 31 MM	818-002	1
21	CIRCLIP 20MM EXTERNAL	804-013	2
22	GRUB SCREW M8 X 10	815-010	1
23	GRUB SCREW M8 X 16	815-002	1
24	PLUG 1/8" BSPT	816-063	3
26	VENT PLUG	113-050	1

**MTA1-S Series Control Valve**

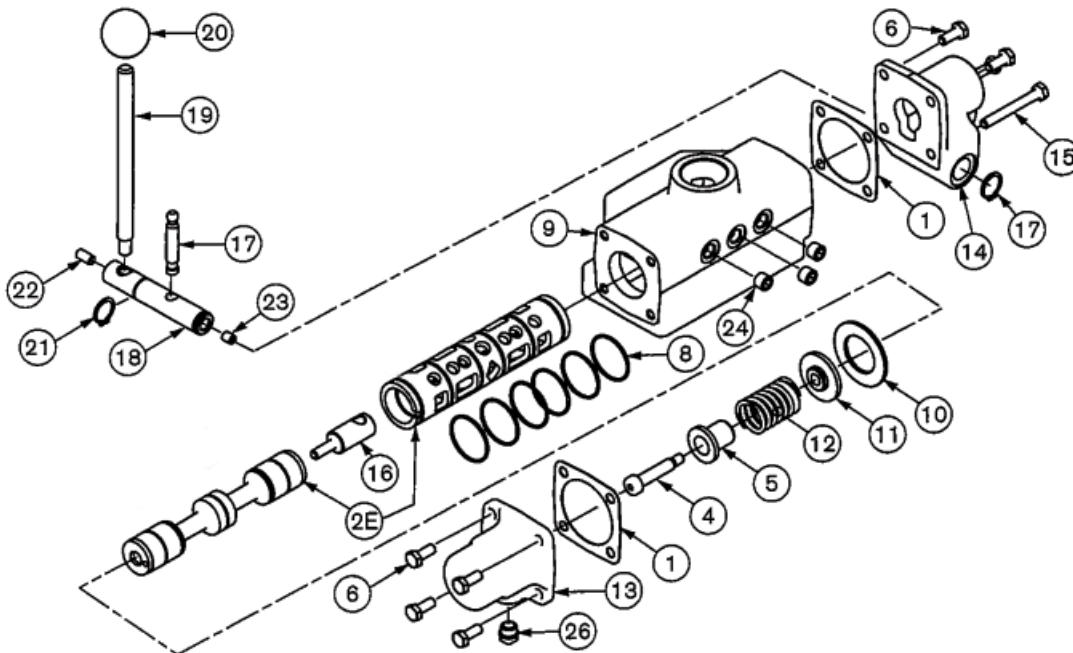

**This page intentionally left blank.**

MTA1-S SERIES - PISTON AIR MOTOR				
item	description	part number	qty	kit no.
1	ROTARY VALVE BEARING (OUTER)	807-020	1	
2	ROTARY VALVE	230-059	1	
3	ROTARY VALVE HOUSING	230-011	1	
4	ROTARY VALVE BEARING (INNER)	807-021	1	
5	ROTARY VALVE BEARING CIRCLIP	804-051	1	
6	ROTARY VALVE HOUSING GASKET	200-001	1*	239-911
7	CYLINDER GASKET	210-030	4*	239-911
8	CYLINDER	210-082	4*	
9	PISTON ASSEMBLY	230-902A	4*	
10	COMPRESSION RING	200-024	4*	239-911
11	OIL CONTROL RING	200-022	4*	239-911
12	KING ROD	230-077	1	
13	CRANKSHAFT SPACER	230-013	1	
14	CRANKSHAFT CIRCLIP	804-009	1	
15	CRANKSHAFT SPACER	300-035	1	
16	CRANKSHAFT SPACER SHIM	300-049	5	
18	CRANKSHAFT BEARING CIRCLIP	804-058	2	
19	CRANKSHAFT OILSEAL	808-044	1*	239-911
20	STD CRANKSHAFT ASSEMBLY	230-915	1	
24	STD FLANGE PLATE	230-076	1	
25	FLANGE PLATE SEAL	808-028	1*	239-911
26	PLUG	816-071	1	
27	ENGINE CASE	230-012	1	
29	QUEEN ROD PIVOT	230-081	3	
30	QUEEN ROD	230-078	3	
31	CRANK SPACER SELECT	230-052	1	
33	CRANK SPACER ASSEMBLY	230-054/055	1	
34	CRANK SPACER	230-056	1	
35	BALANCE WEIGHT	230-010	1	
36	WOODRUFF KEY	811-010	1	
37	CYLINDER BOLTS	802-032	16	
38	VALVE HOUSING BOLTS	802-033	4	
40	ADAPTER PLATER BOLT	802-020	4	
41	EXHAUST COVER BOLTS	802-016	4	
45	SEAL (TRANSIT ONLY)	808-004	1	
46	BREATHER PLUG	130-066	1	
48	NEEDLE BEARING	807-048	1	
49	GRUB SCREW	815-001	1	
50	KEY	811-001	1	
51A	ROTARY VALVE EXHAUST COVER BSP	230-005	1	
51B	ROTARY VALVE EXHAUST COVER NPT	230-105	1	
52	FLANGE BOLTS	810-001	8	
55	OUTPUT SHAFT BEARING (OUTER)	807-007	1	
56	OUTPUT SHAFT BEARING (INNER)	807-008	1	
60	OIL LEVEL PLUG	816-063	1	
72A	INLET ADAPTER PLATE BSP	230-003	1	
72B	INLET ADAPTER PLATE NPT	230-103	1	
73	INLET ADAPTOR PLATE GASKET	130-004	1*	239-911
75	DIPSTICK SEAL	808-008	1*	239-911
	RM510 SEAL KIT	239-911	1	
80	ROTARY VALVE SPACER	230-060	2	

\* Not supplied - optional.



### MTA1-S Series Motor Assembly

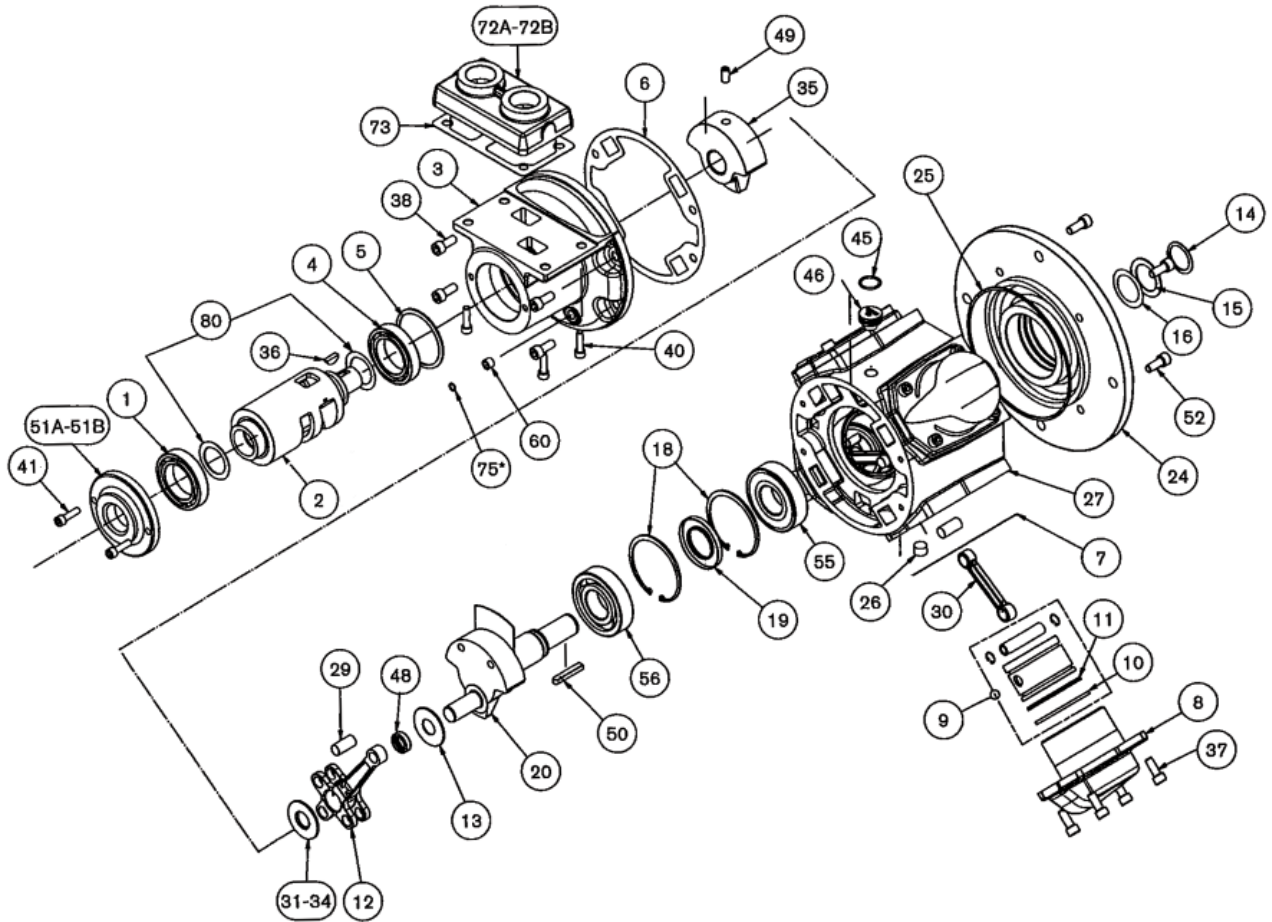

**This page intentionally left blank.**

**This page intentionally left blank.**



***THERN***

**Thern, Incorporated  
5712 Industrial Park Road  
Winona, MN 55987**

**PHN 507-454-2996  
FAX 507-454-5282**

**EMAIL: [info@thern.com](mailto:info@thern.com)  
[www.thern.com](http://www.thern.com)**