

# SHB LOW HEADROOM HAND CHAIN HOIST SERIES

## Lift right when space is tight.

Sometimes there's just not enough room above a load to use a standard hoist. That's where the low profile SHB hoist and trolley combo work where others can't. Built around the quality CB hoist with headrooms as low as 4.5 inches, the SHB is ideal for demanding industrial lifting applications where space is extra tight.



### Ultra Low-Profile Lifting & Maximum Hook Travel

With headroom as low as 4.5 inches, the SHB lets you use every inch of available space. The short headroom feature is specifically engineered to provide maximum hook travel that meets the demands of your constricted lifting application.

### Permanently Attached Hand Geared Trolley

Engineered to function as a single unit, the SHB integrates the proven performance and durability of KITO's standard CB Hoist with a permanently attached, industrial grade, hand-gearred trolley.

### Heavy-Duty Wheels & Steel Side Plates

Heavy-duty lifting applications need heavy-duty equipment that can stand up to your demands. The SHB's cast trolley wheels and structural steel side plates take the weight and provide rigid support and reliability at the same time.

### Maintenance-Free Sealed Trolley Bearings

Focus on the task at hand, not the maintenance of your equipment. The maintenance-free trolley bearings on the SHB are sealed and life-long-lubricated providing you with years of smooth, reliable, quiet operation.

### Adjustable For Tapered or Flat Flanged Beams

Trolley wheels on the SHB are designed to work with both tapered and flat-flanged beams.



WWW.KITO.CA | 1.888.322.KITO (5486)

HAND CHAIN HOISTS | 1

All specifications, dimensions and drawings are available at [www.kito.ca](http://www.kito.ca), or call our Customer Service staff for friendly and expert advice on models and options.

# SHB LOW HEADROOM HAND CHAIN HOIST SERIES

## CAPACITY

- 1 to 10 metric tonnes

## STANDARDS

- ASME B30.16 Safety Standard
- ASME HST-2 Performance Standard
- At rated capacity, load-bearing parts are only stressed to 25% of their limit

## OPTIONS

- Chain bag to keep chain clean and out of the way
- Corrosion resistant chain for tough environments
- Custom lift lengths to suit your requirements

## LOW HEADROOM FEATURES

- Headroom as low as 4.5"
- Built-in trolley with cast wheels, sealed bearings, and steel side plates for heavy-duty applications

## BODY

- Durable all-steel construction
- Rugged gear case and hand wheel cover
- Compact design for low headroom

## HAND CHAIN

- High-quality steel

## LOAD CHAIN

- Heat-treated, low-weight manganese alloy steel
- Grade 100
- High-impact steel chain guide
- Standard Lift: 20 feet

## HOOK

- Forged, heat-treated, opens gradually when overloaded
- Self-closing heavy-duty hook latch

## OPERATION

- Hand chain operated
- Reduced operator fatigue through efficient drive train

## GEARS

- Double reduction gearing requiring very low effort to operate
- Induction heat-treated and case-hardened
- Enclosed to protect from dust and water

## BEARINGS

- Maintenance-free sealed bearings increase reliability and reduce pull force required to lift loads

## BRAKE

- Double pawl springs for extremely reliable operation and instant brake activation
- Enclosed to protect from dust, rain, and dirt

## OPERATING CONDITIONS

- Recommended for -20° to +60 °C



WWW.KITO.CA | 1.888.322.KITO (5486)

HAND CHAIN HOISTS | 2

All specifications, dimensions and drawings are available at [www.kito.ca](http://www.kito.ca), or call our Customer Service staff for friendly and expert advice on models and options.

# SHB LOW HEADROOM HAND CHAIN HOIST

## ULTRA-LOW HEADROOM HAND CHAIN HOIST GEARED TROLLEY MOUNT

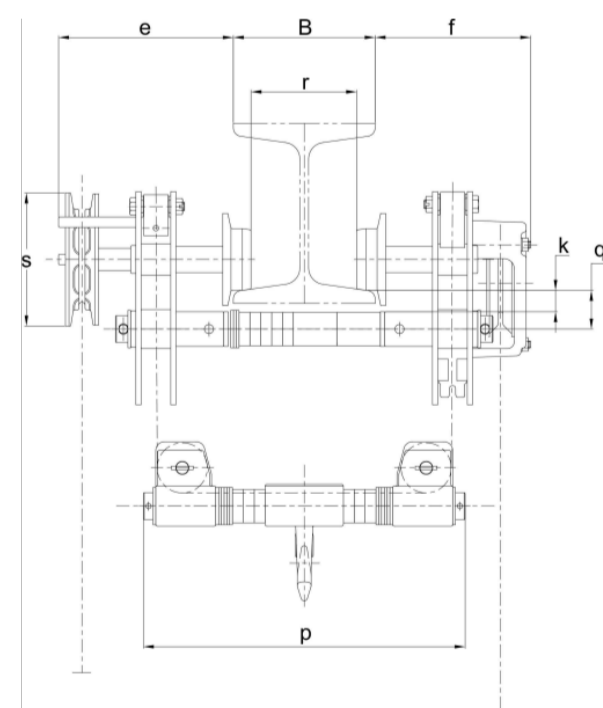

SHB 1 Tonne

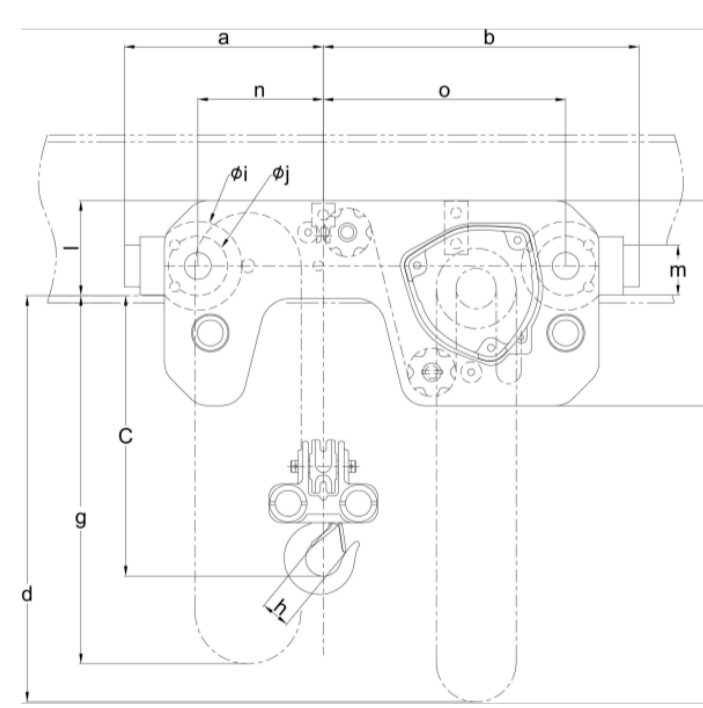

SHB 1 Tonne

\*For informational purposes only, contact KITO for dimensional drawing

2 load chain falls; \*For informational purposes only, contact KITO for dimensional drawing

## DIMENSIONS

Capacity (tonne)	Model	a	b	d	e	f	g	h	i	j	k	l	m	n	o	p	q	r	s
1	SHB010	237	377	5791	201	180	5791	29	106	71	25	114	61	150	290	368	46	B-41	153
2	SHB020	281	436	5791	227	194	5791	36	127	85	31	168	68	180	335	418	53	B-51	153
3	SHB030	340	510	5791	240	207	5791	42.5	148	100	35	177	88	220	390	438	61	B-56	183
5	SHB050	397	587	5791	265	223	5791	46.5	169	118	39	224	97	265	455	514	71	B-74	183
7.5	SHB075	445	638	5791	282	216	5791	62	185	155	33	268	91	300	493	498	84	B-89	214
10	SHB100	445	638	5791	282	216	5791	62	185	155	33	268	91	300	493	498	84	B-89	214

## SPECIFICATIONS

Capacity (tonne)	Model	Standard Lift (ft)	Headroom (in)	Hand Pull to Lift Full Load (kg)	Standard Flange (in)	Load Chain Code	Load Chain Falls	Ship Weight (lbs)	Weight per Additional 5ft of Lift (lbs)
1	SHB010	20	4.5	29	2.3-6.4"	KCF050	2	176	10
2	SHB020	20	5.7	26	3.2-8.0"	KCF071	2	281	14
3	SHB030	20	6.5	34	3.2-8.0"	KCB3080	2	395	16
5	SHB050	20	7.7	41	3.9-8.0"	KCB3090	2	665	19
7.5	SHB075	20	10	44	5.5-8.6"	KCB3090	4	868	31
10	SHB100	20	10	44	5.5-8.6"	KCB3090	4	868	31



WWW.KITO.CA | 1.888.322.KITO (5486)

HAND CHAIN HOISTS | 3

All specifications, dimensions and drawings are available at [www.kito.ca](http://www.kito.ca), or call our Customer Service staff for friendly and expert advice on models and options.