



Current Tools

FOR THE PROFESSIONAL ELECTRICIAN

Current Tools™ Hydraulic Knockout Sets

Model 152 – ½" to 2"

Model 154 – ½" to 4"

and

Model 152 PM – ½" to 2"

Model 154 PM – ½" to 4"

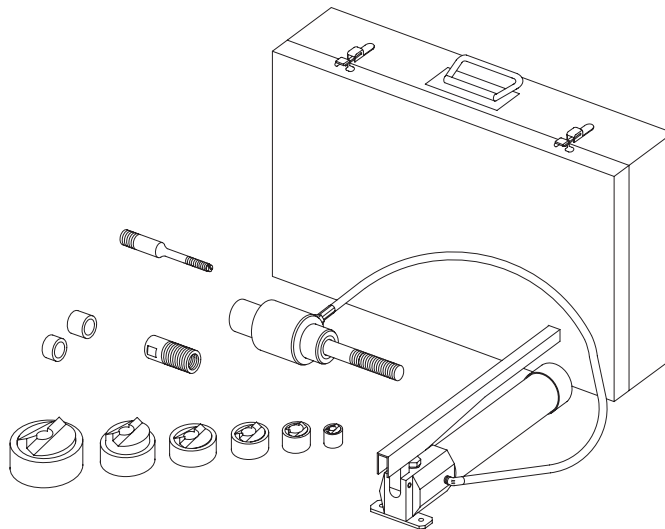

Operating, Maintenance, Safety and Parts Manual

08/10 - REV. 3



Read and understand this material before operating the Hydraulic Knockout Set. Failure to understand how to safely operate and service this unit may result in serious injury or death.

This manual is free of charge. All personnel who operate or service the Hydraulic Knockout Set should have a copy of this manual and read and understand its contents. To request a copy, call or write to the address below.

CURRENT TOOLS • P. O. BOX 17026 GREENVILLE, SC 29606
800.230.5421 or 864-721-4230 • FAX 864-721-4232
www.currenttools.com

TABLE OF CONTENTS

Safety Alerts	2
Safety Information	3-4
Specifications	4
Operating Instructions	4-5
Set-Ups Diagram	6
Components List	7
Section View & Parts List — Model 1522 Ram	8
Specifications — Model 1521 Hand Pump	9
Operating Instructions — Model 1521 Hand Pump	9
Maintenance — Model 1521 Hand Pump	9
Exploded View — Model 1521 Hand Pump	10
Parts List — Model 1521 Hand Pump	11
Repair Kit — Part No.1521-RPRKIT	11

SAFETY ALERTS



Safety Alert Symbol

THIS SAFETY SYMBOL is used to call your attention to instructions that concern your personal safety. It means: ATTENTION! BE AWARE! THIS IS AN IMPORTANT SAFETY INSTRUCTION!

Read, understand, and follow these safety instructions. Failure to follow these safety instructions may result in injury or death.

DANGER

Immediate hazards which, if not avoided, WILL result in serious personal injury or death.

WARNING

Hazards or unsafe practices which, if not avoided, COULD result in serious personal injury or death.

CAUTION

Hazards or unsafe practices which, if not avoided, COULD result in minor personal injury or property damage.

RETAIN SAFETY INFORMATION



This manual should be read and understood by all personnel who operate or service this Hydraulic Knockout Set. Failure to understand how to safely operate and service this unit could result in injury or death. This unit should only be operated or serviced by qualified personnel.



IMPORTANT SAFETY INFORMATION

Follow ALL safety information provided by the manufacturer.

⚠ DANGER

NEVER use the Knockout Set or any of its components near live circuits.

⚠ WARNING

ALWAYS stand to the side of the ram when punching. This will help avoid injury should there be a component failure.

⚠ WARNING

The model 1521 Hand Pump is pre-set at the factory to operate at pressures up to 8,000 PSI. Do NOT connect any pump to the Current Tools model 1522 Ram that will exceed 8,000 PSI. Doing so may cause component failure which may result in injury or death. Only use a hand or foot operated pump with the model 1522 Ram. Never operate the ram with an electric pump.

⚠ WARNING

Be sure to support the ram while punching. An unsupported ram could fall causing injury.

⚠ WARNING

Do NOT continue to operate pump after the ram completes the punch. Doing so will damage the ram and could cause component failure resulting in serious injury or death.

⚠ WARNING

If the ram motion stops before the punching process is completed, Do NOT continue to operate the pump. Release the pump pressure and disassemble the set-up and determine the cause before continuing.

⚠ WARNING

Hydraulic tools create tremendous pressures and hydraulic oil can easily puncture skin. If your skin is pierced by oil you must seek medical attention immediately! NEVER touch the hydraulic hose or fittings while the unit is under pressure.

⚠ WARNING

ALWAYS thread the punch COMPLETELY onto the draw stud (or adapter) to avoid thread failure. If the punch tightens before it is completely threaded onto the draw stud, disassemble the set-up and determine the cause. Then reassemble the set-up.

⚠ WARNING

ALWAYS release the hydraulic pressure before removing any hoses or before servicing any component of the hydraulic system.

⚠ WARNING

ONLY replace the hoses and fittings with Current Tools replacement parts.

⚠ WARNING

NEVER attempt to exceed the punching capacity of this knockout set. Doing so may cause component failure and possibly serious injury or death.

continued on next page . . .

IMPORTANT SAFETY INFORMATION *continued . . .*

▲ WARNING

NEVER attempt to punch a hole through more than a single layer of material. Doing so may cause component failure and possibly serious injury or death.

▲ WARNING

NEVER use this knockout set or any of its components except for its intended purpose.

▲ WARNING

Hand pressure is sufficient to activate the pump. NEVER attempt to apply additional pressure to the pump handle.

▲ WARNING

The Model 1521 Hand Pump is designed for use ONLY with Hydraulic Knockout Sets and Cable Cutters.

▲ CAUTION

ALWAYS inspect every component of the punch set-up including the ram, pump, fittings, punch, die, draw stud, adapter, and spacer(s) before each use. Replace any worn or defective parts with Current Tools replacement parts. NEVER use dull punches.

▲ CAUTION

NEVER use any component that has worn or damaged threads.

▲ CAUTION

ALWAYS check to ensure all components are properly assembled before punching.

▲ CAUTION

New punches are sharp. Be careful when handling them.

▲ CAUTION

ALWAYS wear safety glasses when punching.

SPECIFICATIONS

Model No.	152 and 152PM	154 and 154PM
Overall Dimensions	4 $\frac{1}{8}$ " x 10 $\frac{1}{2}$ " x 17 $\frac{3}{4}$ "	4 $\frac{1}{8}$ " x 14" x 17 $\frac{3}{4}$ "
Capacity	$\frac{1}{2}$ " to 2" <i>conduit size holes</i>	1/2" thru 4" <i>conduit size holes</i>
Weight	25 lbs.	54 lbs.

The model 1521 Hydraulic Hand Pump has a maximum operating pressure of 8,000 PSI.

NOTE: All models are designed to punch a maximum of 10 gauge mild steel (.134 in. thick)

Current Tools™ Models 152PM and 154PM — Piece Makers™ — are designed to split the slug into two pieces for easy removal from the die after punch completion.

OPERATING INSTRUCTIONS

1. Match the punch, die, draw stud, adapter (if needed) , and spacer(s) as required for the size hole to be punched. (*See Figures 1a, 1b, 1c.*)
2. After marking the hole location, drill a hole approximately $\frac{1}{32}$ " to $\frac{1}{16}$ " larger than the draw stud or adapter being used.

NOTE: *Alternate Method* — Drill a $\frac{7}{16}$ " hole to accept the $\frac{3}{8}$ " adapter draw stud (Part #1581) and use the $\frac{1}{2}$ " punch and die to increase the hole size to accept the $\frac{3}{4}$ " draw stud (Part #1582). Then, if needed, use 1" punch and die to increase the hole size to accept the $1\frac{1}{8}$ " adapter.

continued on next page . . .

OPERATING INSTRUCTIONS *continued . . .*

- When using $\frac{3}{4}$ " through 3" punch and die, thread the end of the $\frac{3}{4}$ " draw stud (Part #1582) with the shortest thread length into the ram until snug. (See Figure 1b.)

When using the $\frac{1}{2}$ " punch and die, thread the larger $\frac{3}{4}$ " end of the $\frac{3}{8}$ " adapter draw stud (Part #1581) directly into the ram until snug. (See Figure 1a.)

When using the $3\frac{1}{2}$ " and 4" punch and die, thread the $1\frac{1}{8}$ " adapter (Part #1552) over the $\frac{3}{4}$ " draw stud (Part #1582) until snug. The threaded end of the $1\frac{1}{8}$ " adapter should face away from the ram. (See Figure 1c.)

- Determine spacer(s) needed (if any) and install. (See *Spacer Chart below.*)

SPACER CHART	
Punch & Die Size	Spacers
$\frac{1}{2}$ "	SHORT (#1553)
$\frac{3}{4}$ " thru $1\frac{1}{4}$ "	MEDIUM (#1554)
$1\frac{1}{2}$ "	SHORT (#1553)
2" thru 4"	No spacers

- Slide the die onto the draw stud with the open end of the die facing away from the ram.
- Place the draw stud through the hole you drilled in step 2. Then thread the punch onto the draw stud (*or adapter*) with the cutting face toward the material to be punched. Thread the punch onto the draw stud until the punch, die and spacers are snug against the material.

WARNING

ALWAYS thread the punch COMPLETELY onto the draw stud (or adapter) to avoid thread failure. If the punch tightens before it is completely threaded onto the draw stud, disassemble the set-up and determine the cause. Then reassemble the set-up.

- Complete the punching process by activating the hand pump. (See *hand pump operating instructions on page 9.*)

WARNING

- DO NOT continue to operate the pump after the ram completes the punch. Doing so will damage the ram and could cause component failure resulting in serious injury or death.
- If the ram motion stops before the punching process is completed, DO NOT continue to operate the pump. Release the pump pressure and disassemble the set-up and determine the cause before continuing.
- Be sure to support the weight of the ram while punching. An unsupported ram could fall causing injury.

SET UPS

EXPLODED VIEW

COMPLETED VIEW

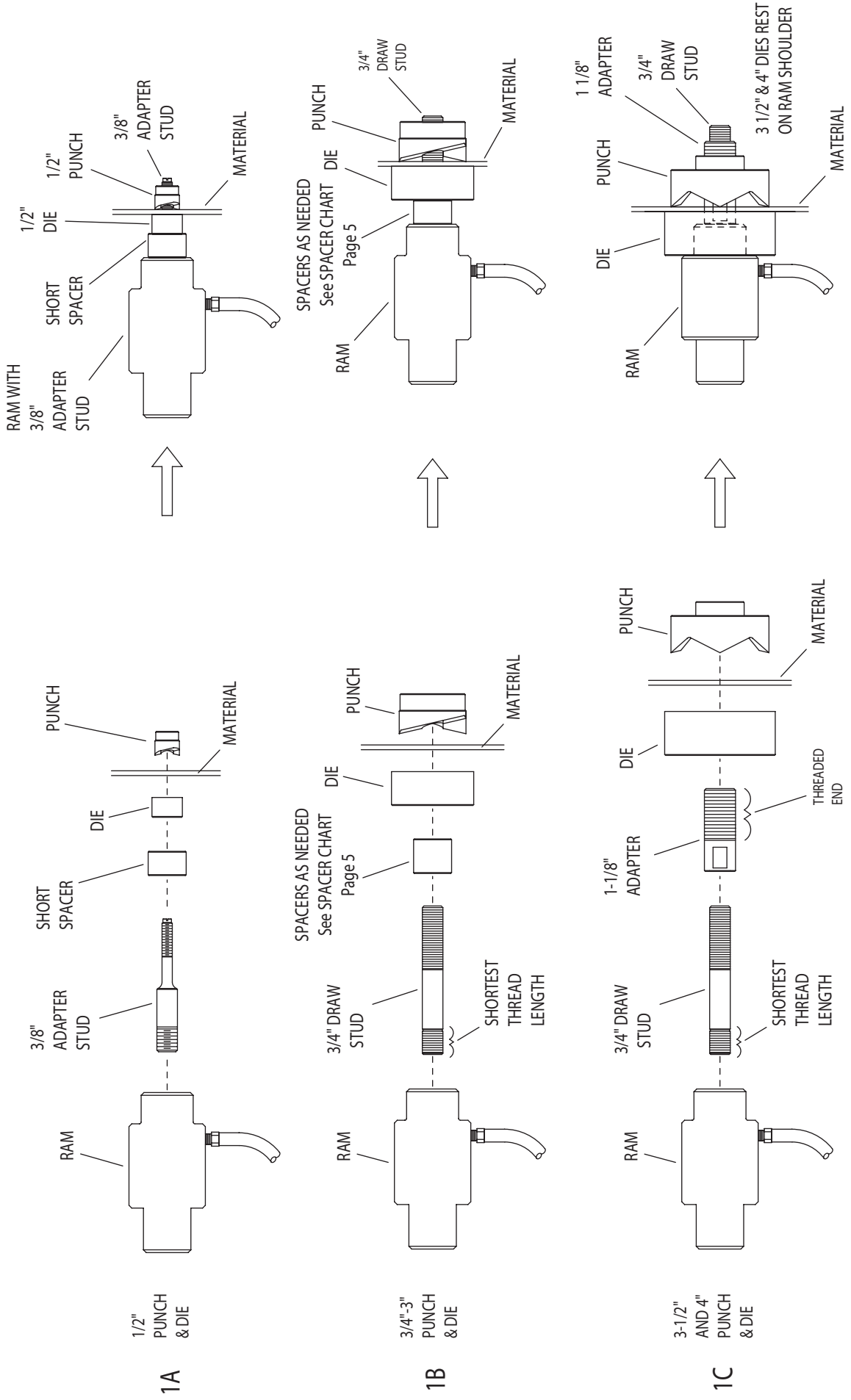
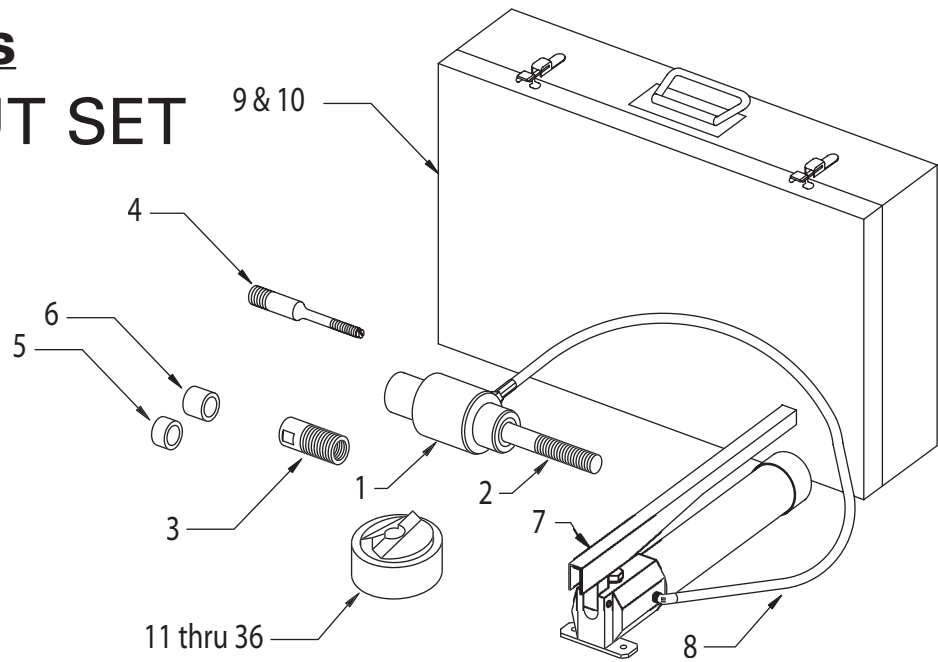

FIGURE 1

COMPONENTS

KNOCKOUT SET



COMPONENTS LIST

ITEM#	CATALOG#	DESCRIPTION	#152 1/2" to 2"	#152PM 1/2" to 2"	#154 1/2" to 4"	#154PM 1/2" to 4"
1.....	1522	Ram (Includes #2)	1	1	1	1
2.....	1582	3/4" Draw Stud	1	1	1	1
3.....	1552	1/8" Adapter	1	1	1	1
4.....	1581	3/8" Adapter Draw Stud	1	1	1	1
5.....	1553	Short Spacer - S	1	1	1	1
6.....	1554	Medium Spacer - M	1	1	1	1
7.....	1521	Hydraulic Hand Pump	1	1	1	1
8.....	1523	1/4" x 3' Hydraulic Hose	1	1	1	1
9.....	1500-PC	Plastic Carrying Case - 1/2" to 2" Set	1	1		
10.....	1501	Metal Carrying Case - 1/2" to 4" Set			1	1
11.....	1524	1/2" Piece Maker™ Punch		1		1
12.....	1525	1/2" Die	1	1	1	1
13.....	1526	3/4" Piece Maker™ Punch		1		1
14.....	1527	3/4" Die	1	1	1	1
15.....	1528	1" Piece Maker™ Punch		1		1
16.....	1529	1" Die	1	1	1	1
17.....	1530	1 1/4" Piece Maker™ Punch		1		1
18.....	1531	1 1/4" Die	1	1	1	1
19.....	1532	1 1/2" Piece Maker™ Punch		1		1
20.....	1533	1 1/2" Die	1	1	1	1
21.....	1534	2" Piece Maker™ Punch		1		1
22.....	1535	2" Die	1	1	1	1
23.....	1560	1/2" Standard Punch	1		1	
24.....	1561	3/4" Standard Punch	1		1	
25.....	1562	1" Standard Punch	1		1	
26.....	1563	1 1/4" Standard Punch	1		1	
27.....	1564	1 1/2" Standard Punch	1		1	
28.....	1565	2" Standard Punch	1		1	
29.....	1566	2 1/2" Punch			1	1
30.....	1567	2 1/2" Die			1	1
31.....	1568	3" Punch			1	1
32.....	1569	3" Die			1	1
33.....	1570	3 1/2" Punch			1	1
34.....	1571	3 1/2" Die			1	1
35.....	1572	4" Punch			1	1
36.....	1573	4" Die			1	1

SECTION VIEW

MODEL 1522 RAM

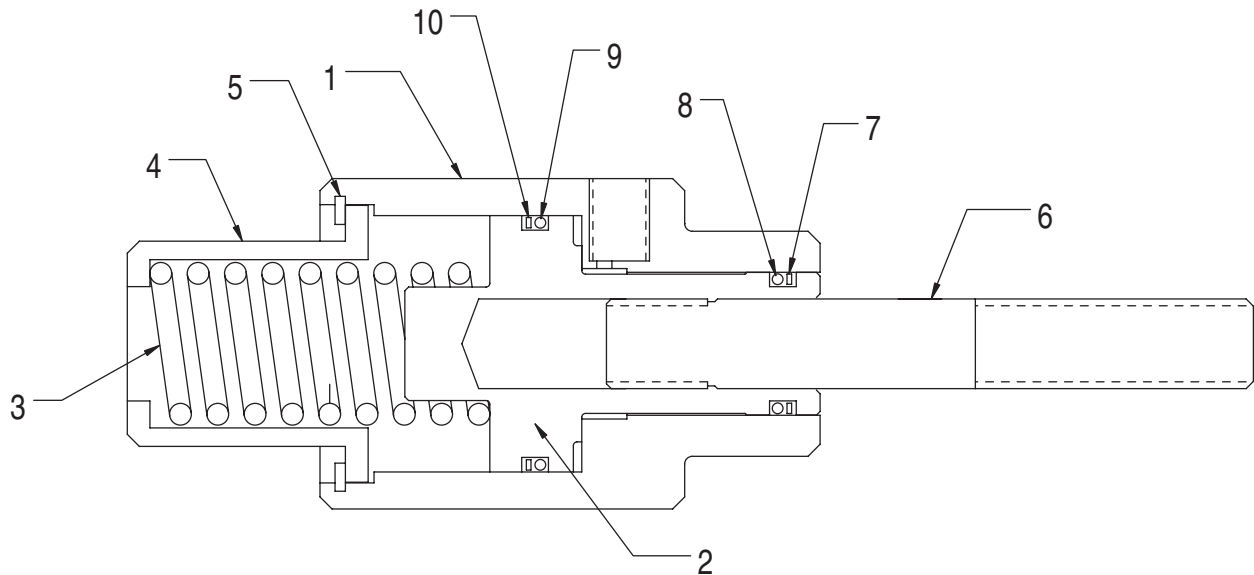

PARTS LIST — Model 1522 Ram

ITEM#	PART#	QTY	DESCRIPTION
1	1522-11.....	1	CYLINDER
2	1522-12.....	1	PISTON
3	1522-2.....	1	SPRING
4	1522-4.....	1	CAP
*5	1522-5.....	1	RETAINING RING
6	1582	1	3/4" DRAW STUD
*7	1522-7.....	1	BACK-UP RING
*8	1522-8.....	1	O-RING
*9	1522-9.....	1	O-RING
*10	1522-10.....	1	BACK-UP RING

* Included in Repair Kit Part Number 1522-RPR

SPECIFICATIONS — MODEL 1521 HAND PUMP

WARNING

The Model 1521 Hand Pump is designed for use ONLY with Hydraulic Knockout Sets and Cable Cutters.

Model No.	1521 Hand pump
Overall Dimensions	2 ⁷ / ₈ " Wide x 3 ⁷ / ₈ " Tall x 12 ³ / ₄ " Long
Capacity	8,000 PSI max — .069 cu. in. of oil per stroke
Weight	4.5 lbs. (with oil)
Oil Capacity	16 cu. in.

OPERATING INSTRUCTIONS

1. Turn knob clockwise.
2. Pump handle to activate hand pump.
3. When operation is complete, turn knob counter-clockwise.

WARNING

Hand pressure is sufficient to activate the pump. NEVER attempt to apply additional pressure to the pump handle.

MAINTENANCE

Oil Requirements: We recommend a high quality automatic transmission fluid such as Shell DONAX TG or equivalent

Filling the Pump with Oil:

1. Secure the pump in a vise by clamping lightly onto the hex body with the reservoir and end cap facing upward, and unscrew the end cap.
2. Remove the rubber plug located in the center of the reservoir follower, and then remove the reservoir follower. Check the reservoir follower O-ring and the rubber plug for damage or wear, and replace as needed.
3. Fill the reservoir until the oil level is ³/₄" from the top.
4. Push the reservoir follower into the reservoir until oil begins to come out of the hole.
5. To remove trapped air from the pump, turn the release knob clockwise to the closed position and pump the handle 5 times. Slowly turn the release knob counterclockwise while keeping light pressure with your finger over the hole in the reservoir follower. This allows air to escape under your finger and prevents ejecting oil. Repeat this procedure if needed.
6. Replace the rubber plug in the reservoir follower.
7. Remove and clean the felt vent located inside the reservoir end cap. Then screw the reservoir end cap back onto the reservoir.

MODEL 1521 HAND PUMP

EXPLODED VIEW

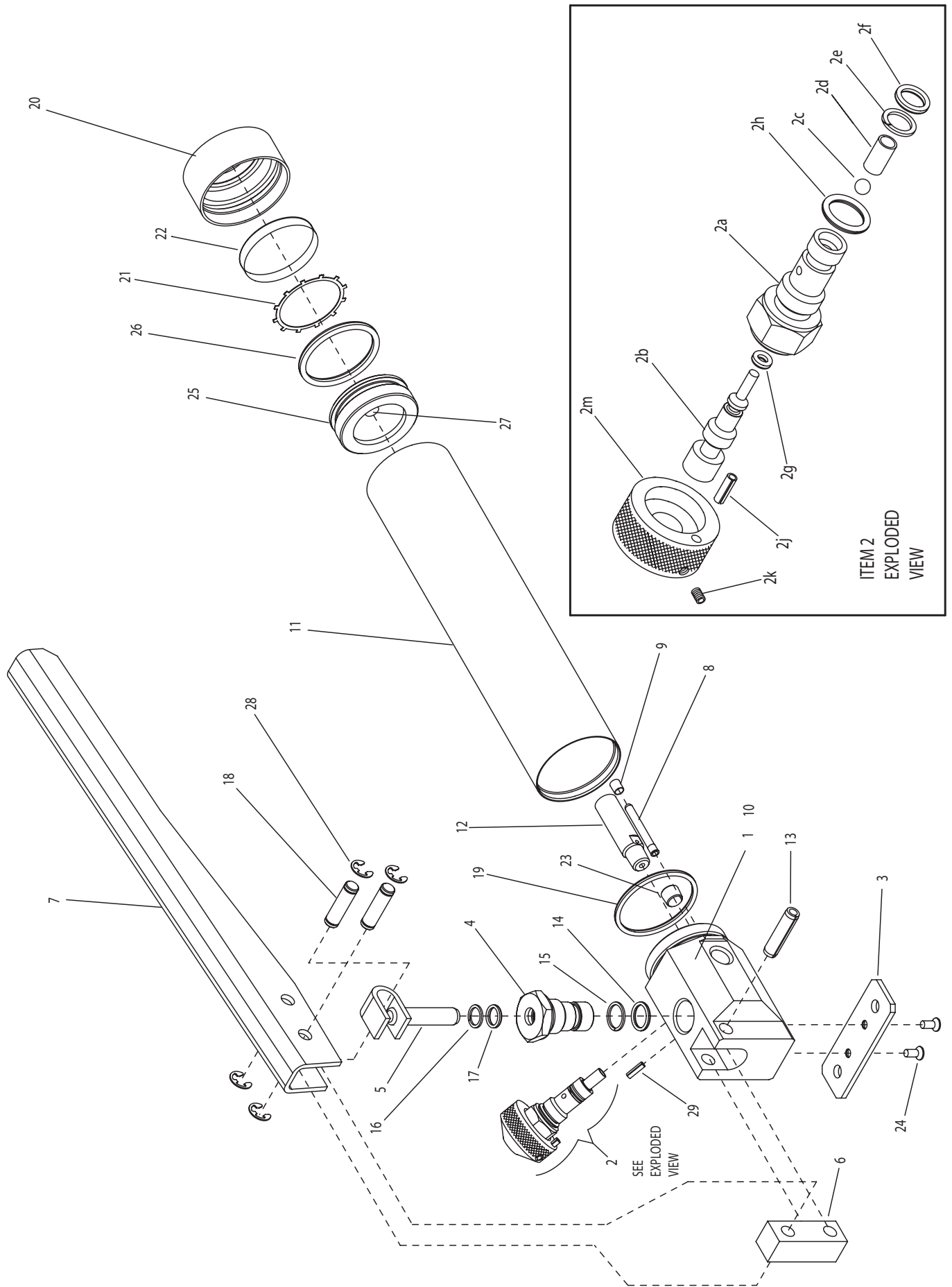



PARTS LIST — Model 1521 Hand Pump

ITEM #	PART #	QTY	DESCRIPTION
1	1521-1	1	BODY
2	1521-2	1	RELEASE ASSEMBLY
2a	1521-2a	1	RELEASE BODY
2b	1521-2b	1	SCREW
2c	1521-1d	1	BALL
2d	1521-2d	1	SPRING RELEASE
2e	1521-2e	1	BACK UP RING
2f	1521-2f	1	O-RING
2g	1521-2g	1	O-RING
2h	1521-2h	1	O-RING
2j	1521-2j	1	ROLL PIN
2k	1521-2k	1	SET SCREW
2m	1521-2m	1	KNOB
3	1521-3	1	FOOT
4	1521-4	1	PISTON RETAINER
5	1521-5	1	PISTON DOWEL
6	1521-6	1	HANDLE LINK
7	1521-7	1	HANDLE
8	1521-8	1	SCREEN
9	1521-9	1	SCREEN RETAINER
10	1521-10	2	CHECK VALVE
11	1521-11	1	RESERVOIR
12	1521-12	1	RELIEF VALVE
13	1521-13	1	SPRING PIN
14	1521-14	1	O-RING
15	1521-15	1	BACK UP RING
16	1521-16	1	BACK UP RING
17	1521-17	1	O-RING
18	1521-18	2	HANDLE PIN
19	1521-19	1	O-RING
20	1521-20	1	RESERVOIR CAP
21	1521-1B	1	RETAINING CLIP
22	1521-1C	1	FELT VENT
23	1521-23	1	PLUG
24	1521-1A	2	SCREW
25	1521-25	1	RESERVOIR PISTON
26	1521-26	1	O-RING
27	1521-27	1	RUBBER PLUG
28	1521-28	4	RETAINING RING
29	1521-29	1	ROLL PIN

REPAIR KIT PART #1521-RPRKIT Contains the following:

14	1521-14	1	O-RING
15	1521-15	1	BACK UP RING
16	1521-16	1	BACK UP RING
17	1521-17	1	O-RING
19	1521-19	1	O-RING
26	1521-26	1	O-RING
27	1521-27	1	RUBBER PLUG
2e	1521-2e	1	BACK UP RING
2f	1521-2f	1	O-RING
2g	1521-2g	1	O-RING
2h	1521-2h	1	O-RING