



Current Tools

FOR THE PROFESSIONAL ELECTRICIAN

Hook Type Sheaves

Models 406, 412, 418, 424, 4424 – 4,000 LB capacity

Models 812, 818, 824, 836 – 8,000 LB capacity

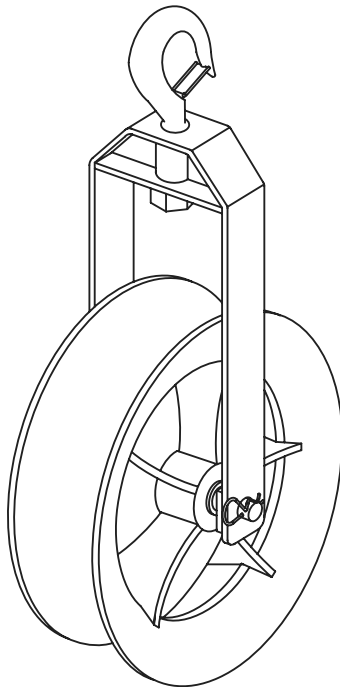

Operating, Maintenance, Safety and Parts Manual

02/14 REV. 0



Read and understand this material before operating or servicing this sheave. Failure to understand how to safely operate and service this sheave may result in serious injury or death.

This manual is free of charge. All personnel who operate this sheave should have a copy of this manual and read and understand its contents. To obtain a copy, call, write to the address below, or visit our website. All information, specifications and product designs may change due to design improvements or updates and are subject to change without notice. Current Tools does not assume any liability for damages resulting from misuse or incorrect application of its products.

CURRENT TOOLS • P. O. BOX 17026 GREENVILLE, SC 29606
800.230.5421 or 864.721-4230 • FAX 864.721.4232
www.currenttools.com

TABLE OF CONTENTS

<i>Safety Alerts</i>	2
<i>Safety Information</i>	3
<i>Hook Load Illustrations & Calculations</i>	4-7
<i>Hook Warning & Applications</i>	8-9
<i>Parts List — Models 406, 412, 418, 424, 4424</i>	10
<i>Parts List — Models 812, 818, 824, 836</i>	11

SAFETY ALERTS



Safety Alert Symbol

THIS SAFETY SYMBOL is used to call your attention to instructions that concern your personal safety. It means: ATTENTION! BE AWARE! THIS IS AN IMPORTANT SAFETY INSTRUCTION!

Read, understand and follow these safety instructions. Failure to follow these safety instructions may result in injury or death.

DANGER

Immediate hazards which, if not avoided, WILL result in serious personal injury or death.

WARNING

Hazards or unsafe practices which, if not avoided, COULD result in serious personal injury or death.

CAUTION

Hazards or unsafe practices which, if not avoided, COULD result in minor personal injury or property damage.

RETAIN SAFETY INFORMATION



This manual should be read and understood by all personnel who operate or service this sheave. Failure to understand how to safely operate and service this unit could result in injury or death. This unit should only be operated or serviced by qualified personnel.



IMPORTANT SAFETY INFORMATION

Follow ALL safety information provided by the manufacturer.

⚠ WARNING

Be aware that a cable puller may exert up to **twice** its rated capacity on any component in the puller set-up.

⚠ WARNING

ALWAYS inspect the structural integrity of any supporting conduit, anchoring system, etc. that will hold the hook sheave during the pull. These supports should be able to withstand **twice** the maximum pulling force of the cable puller.

⚠ WARNING

Rope must ALWAYS be pulled over a rotating sheave. If a sheave does not rotate, turn cable puller off immediately and determine the cause before continuing pull.

⚠ WARNING

All instructions and safety information supplied with the cable puller must be read and understood. Failure to understand how to safely operate and service the cable puller could result in serious injury or death.

⚠ WARNING

Hook sheaves are for use in cable pulling only. DO NOT use for lifting personnel or equipment. Failure to observe this warning could result in serious injury or death.

⚠ CAUTION

The angle of the pulling rope over the sheave will help you calculate the load being applied to the hook sheave and its support structure. Be sure to determine this load prior to making a pull, and be certain the hook sheave and support structure can handle the load. (See pages 4-7 for help with calculating loads).

⚠ CAUTION

Read and understand the cable manufacturer's specifications for minimum bending radius for the cable being pulled. Using incorrect size sheaves can damage the cable.

⚠ CAUTION

ALWAYS wear safety glasses. Failure to wear eye protection could result in eye injury from flying debris.

DETERMINING HOOK LOAD

The tension (T) on both sides of a rope as it crosses over a sheave add together to generate the load on a hook and it's anchoring and structural supports. This load (L) varies depending on both the tension and the angle (A) of the rope as it crosses over the sheave.

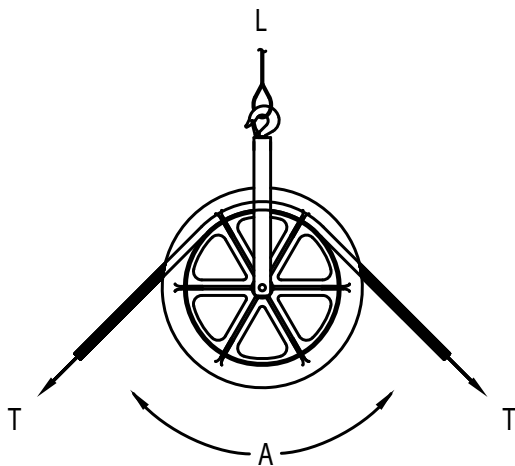

L = the load which is exerted on the hook and all it's anchor points and structural supports

A = the angle made between the rope as it crosses over the sheave

T = the tension on the rope created by the cable puller

REFERENCE CHART

ILLUSTRATION	ANGLE (A)	LOAD (L)
	180°	0
	150°	0.52 x T
	135°	0.77 x T
	120°	1 x T
	90°	1.41 x T
	60°	1.73 x T
	45°	1.85 x T
	30°	1.93 x T
	0°	2 x T

HOOK LOAD ILLUSTRATIONS

A STRAIGHT ROPE ON THE SHEAVE EXERTS **NO LOAD ON THE HOOK**

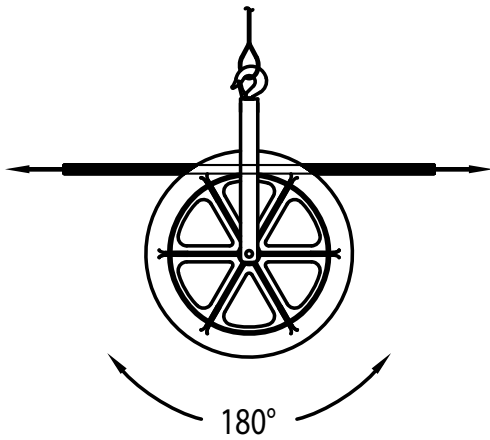

A ROPE AT AN ANGLE OF 150° EXERTS A **HOOK LOAD EQUAL TO 1/2 OF THE PULLING FORCE.**

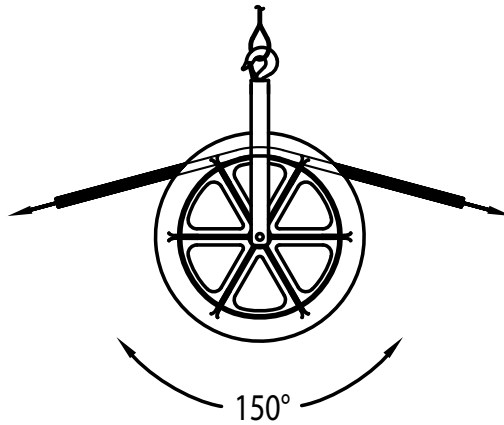

A ROPE AT AN ANGLE OF 135° EXERTS A **HOOK LOAD EQUAL TO 3/4 OF THE PULLING FORCE.**

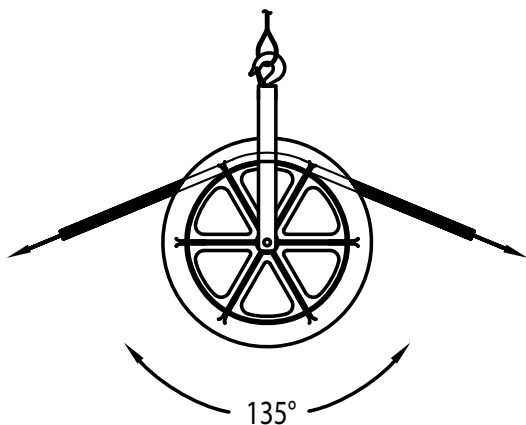

A ROPE AT AN ANGLE OF 120° EXERTS A **HOOK LOAD EQUAL TO THE PULLING FORCE.**

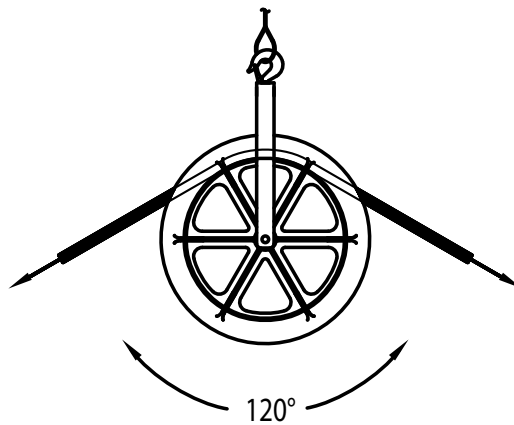

A ROPE AT AN ANGLE OF 90° EXERTS A **HOOK LOAD EQUAL TO 1-1/2 TIMES THE PULLING FORCE.**

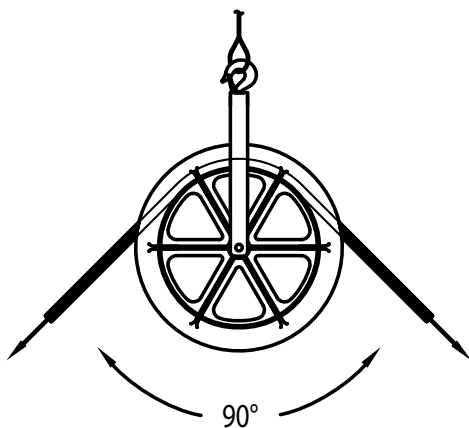

A ROPE AT AN ANGLE OF 0° EXERTS A **HOOK LOAD EQUAL TO 2 TIMES THE PULLING FORCE.**

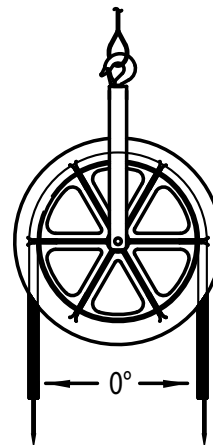

HOOK LOAD (L) CALCULATIONS

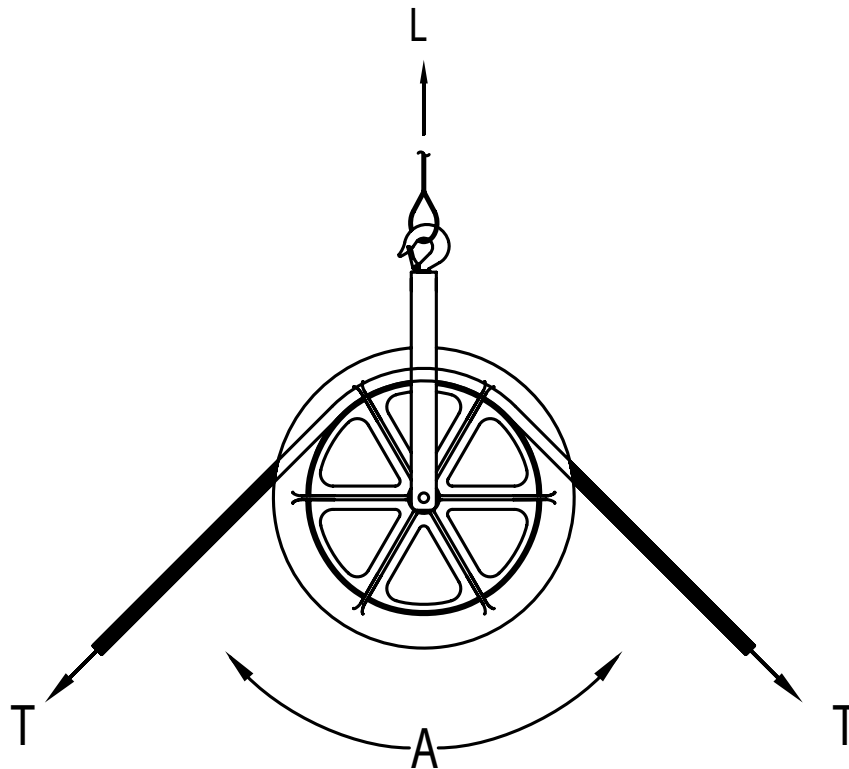

SINGLE ATTACHMENT POINT

$$L = 2 \times T \times \sin[(180-A)/2]$$

WHERE:

L = the load which is exerted on the hook and all its anchor points and structural supports

A = the angle made between the rope as it crosses over a sheave

T = the tension on the rope created by the cable puller

NOTE: WEIGHT OF SHEAVE MUST BE ADDED TO THE CALCULATED LOAD (L) FOR TOTAL LOAD ON SUPPORT STRUCTURE.

HOOK LOAD (L) CALCULATIONS

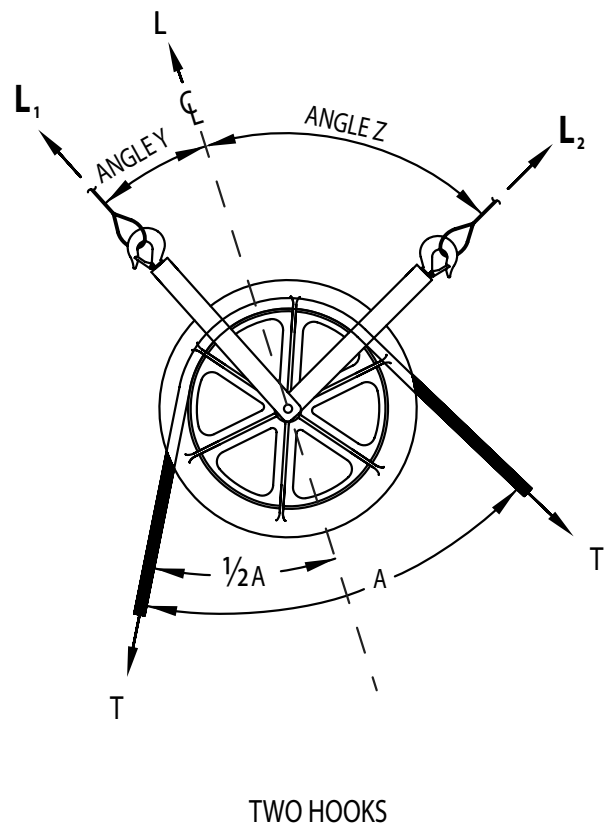
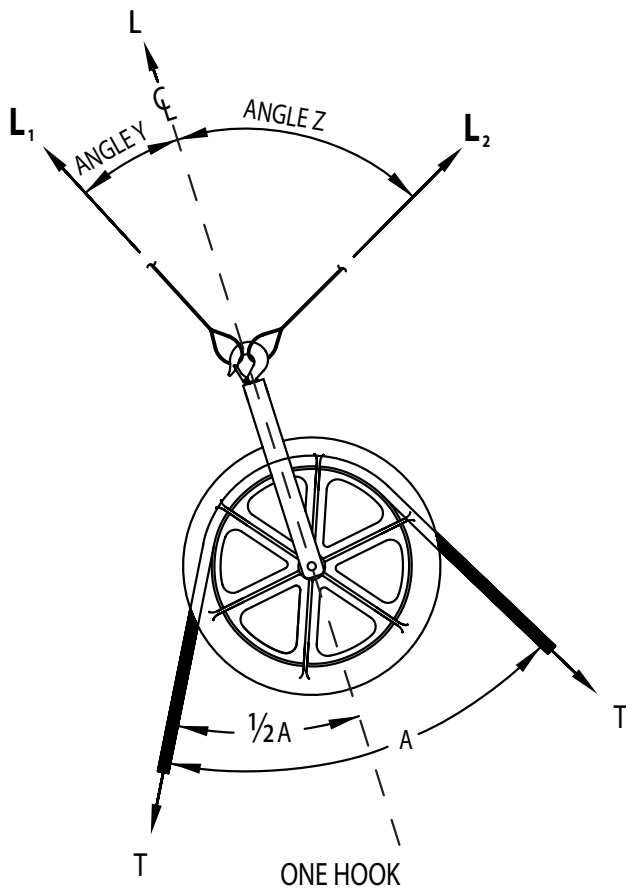

TWO ATTACHMENT POINTS (WITH EITHER ONE OR TWO HOOKS)

STEP 1
CALCULATE LOAD AT CENTERLINE

$$L = 2 \times T \times \sin[(180-A)/2]$$

WHERE:

L = the load which is exerted at the centerline

A = the angle made between the rope as it crosses over a sheave

T = the tension on the rope created by the cable puller

STEP 2
CALCULATE LOAD AT LEFT (L₁)

$$L_1 = \frac{L}{\cos Y + \sin Y / \tan Z}$$

WHERE:

L₁ = the load at the left hook or left support

L = the load which is exerted at the centerline

Y = the angle made between the left hook or support and the centerline.

Z = the angle made between the right hook or support and the centerline

STEP 3
CALCULATE LOAD AT RIGHT (L₂)

$$L_2 = \frac{L}{\cos Z + \sin Z / \tan Y}$$

WHERE:

L₂ = the load at the right hook or right support

L = the load which is exerted at the centerline

Y = the angle made between the left hook or support and the centerline.

Z = the angle made between the right hook or support and the centerline

NOTE: WEIGHT OF SHEAVE MUST BE ADDED TO THE CALCULATED LOADS IN ALL CASES

CROSBY® HOIST HOOK

WARNING AND APPLICATION INSTRUCTIONS

⚠ WARNING

- Loads may disengage from hook if proper procedures are not followed.
- A falling load may cause serious injury or death.
- Hook must always support the load. The load must never be supported by the latch.
- Read and understand these instructions before using hook.

IMPORTANT SAFETY INFORMATION – READ AND FOLLOW

- A visual periodic inspection for cracks, nicks, wear, gouges and deformation as part of a comprehensive documented inspection program, should be conducted by trained personnel in compliance with the schedule in ANSI B30.10. Refer to ANSI B30.10 – hooks for additional information.
- Never use a hook whose throat opening has been increased, or whose tip has been bent more than 10 degrees out of plane from the hook body, or is in any other way distorted or bent. **Note: A latch will not work properly on a hook with a bent or worn tip.**
- Never use a hook that is worn beyond the limits shown in Figure 1.
- Remove from service any hook with a crack, nick, or gouge. Hooks with a nick or gouge shall be repaired by trained personnel by grinding lengthwise, following the contour of the hook, provided that the reduced dimension is within the limits shown in Figure 1. Contact Crosby Engineering to evaluate any crack.
- Never repair, alter, rework, or reshape a hook by welding, heating, burning, or bending.
- Never side load, back load, or tip load a hook. (Side loading, back loading and tip loading are conditions that damage and reduce the capacity of the hook). (See Figure 2.)
- Always make sure the hook supports the load. (See Figure 3). The latch must never support the load (See Figure 4).
- When placing two (2) sling legs in hook, make sure the angle from the vertical to the outermost leg is not greater than 45 degrees, and the included angle between the legs does not exceed 90 degrees (See Figure 5). For two legged slings with angles greater than 90 degrees, use an intermediate link such as a master link or bolt type shackle to collect the legs of the slings. The intermediate link can be placed over the hook to provide an in-line load on the hook. This approach must also be used when using slings with three or more legs.

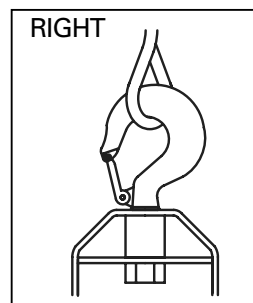
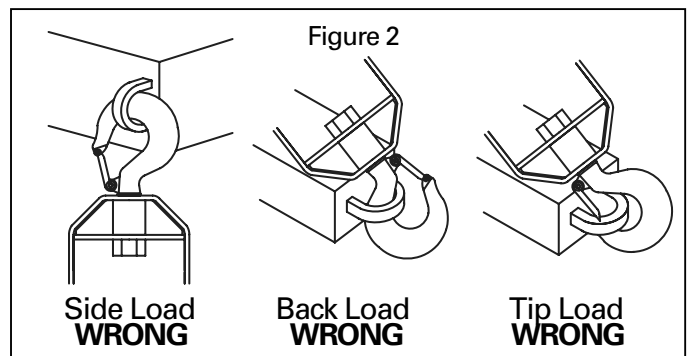
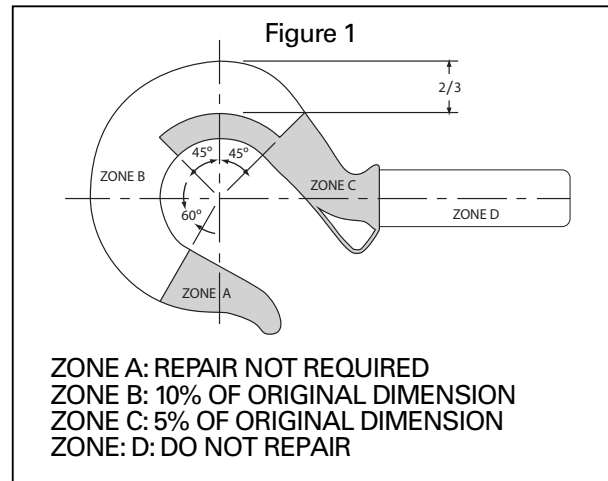

Figure 3

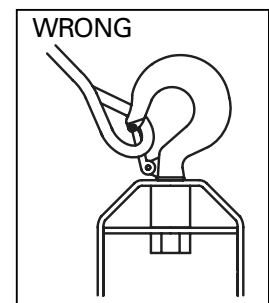

Figure 4

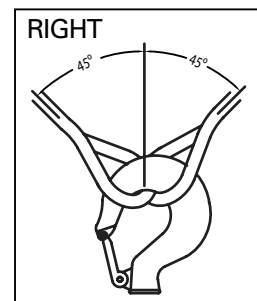

Figure 5

HOOK LATCH KIT

WARNING AND APPLICATION INSTRUCTIONS

IMPORTANT SAFETY INFORMATION – READ AND FOLLOW



- Always inspect hook and latch before using.
- Never use a latch that is distorted or bent.
- Always make sure spring will force the latch against the tip of the hook.
- Always make sure hook supports the load. The latch must never support the load. (See Figure 1 & 2.)
- When placing two (2) sling legs in hook, make sure the angle between the legs is less than 90° and if the hook or load is tilted, nothing bears against the bottom of the latch. (See Figure 3 & 4.)
- Latches are intended to retain loose sling or devices under slack conditions.
- Latches are not intended to be an anti-fouling device.



WARNING

- Loads may disengage from hook if proper procedures are not followed.
- A falling load may cause serious injury or death.
- Hook must always support the load. The load must never be supported by the latch.
- DO NOT use this latch in applications requiring non-sparking.
- Read and understand these instructions before using hook and latch.

WRONG

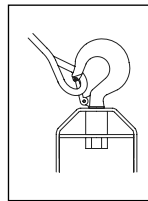

Figure 1

RIGHT

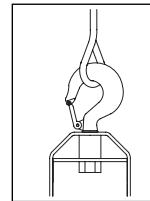

Figure 2

WRONG

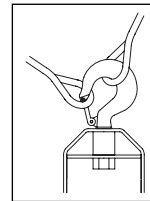

Figure 3

RIGHT

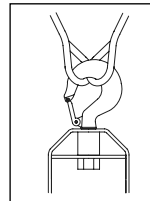
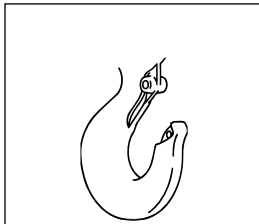

Figure 4

IMPORTANT – Instructions for Assembling Latch on Hooks



Step 1

1. Place hook at approximately a 45 degree angle with the cam up.

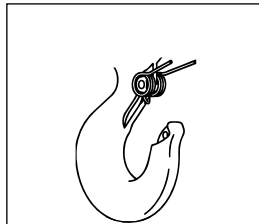

Step 2

2. Position coils of spring over cam with legs of spring pointing toward point of hook and loop of spring positioned down and lying against the hook.

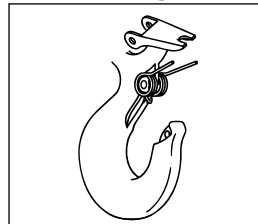

Step 3

3. Position latch to side of hook points. Slide latch onto spring legs between lockplate and latch body until latch is partially over hook cam. Then depress latch and spring until latch clears point of hook.

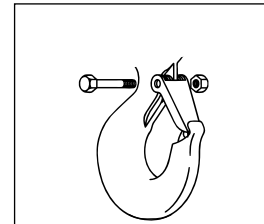

Steps 4, 5, & 6

4. Line up holes in latch with hook cam.
5. Insert bolt through latch, spring, and cam.
6. Tighten self-locking nut on one end of bolt.

DIMENSIONS AND PARTS LIST

4,000 LB Capacity Hook Sheaves Models 406, 412, 418, 424 and 4424

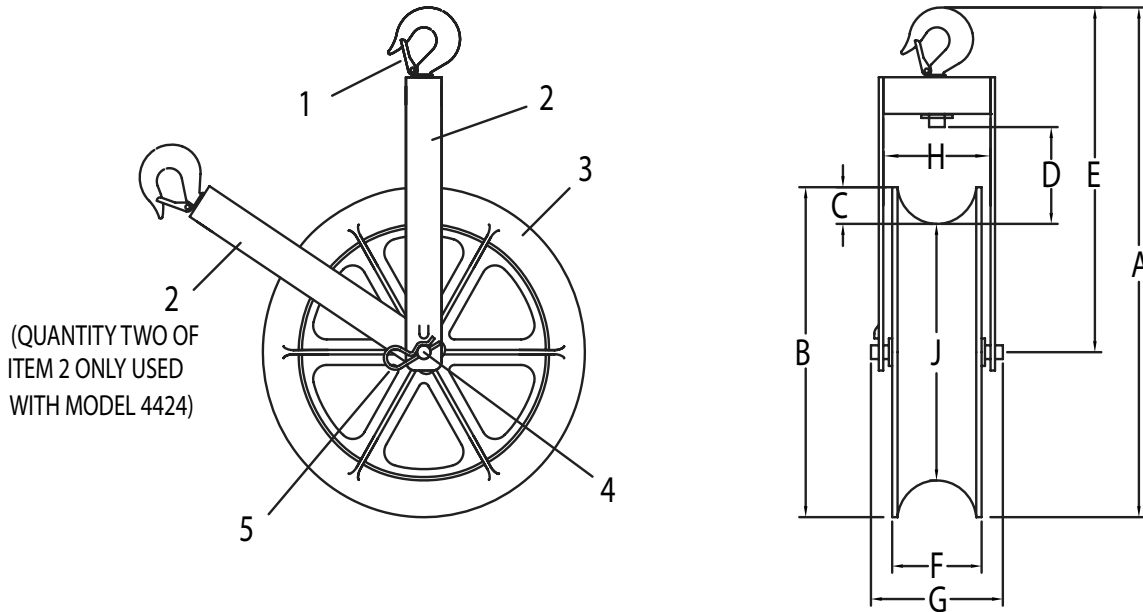

(QUANTITY TWO OF
ITEM 2 ONLY USED
WITH MODEL 4424)

DIMENSIONAL CHART

	MODEL NUMBERS				
	406	412	418	424	4424
A	15.93	21.25	27.93	33.93	33.93
B	6.00	10.63	18.00	24.00	24.00
C	1.50	2.25	2.00	2.25	2.25
D	4.90	6.34	5.40	5.66	5.66
E	12.93	15.93	18.93	21.93	21.93
F	5.00	5.00	5.00	5.00	5.00
G	6.88	6.88	6.88	6.88	7.38
H	5.50	5.50	5.50	5.50	5.50
J	3.00	6.13	14.00	19.50	19.50
WEIGHT LBS	11.5	18.5	28	38	50

ALL DIMENSIONS IN INCHES

PARTS LIST

ITEM	DESCRIPTION	MODEL NUMBERS				
		406	412	418	424	4424
1	LATCH KIT	406-1A1	406-1A1	406-1A1	406-1A1	406-1A1
2	YOKE FRAME	406-190	412-191	418-192	424-193	424-193
3	SHEAVE	406-4	412-4	418-4	424-4	424-4
4	PIN-SHEAVE	406-362	406-362	406-362	406-362	333-212
5	SPRING CLIP	406-3	406-3	406-3	406-3	406-3
6	MODEL NO. DECAL (not shown)	406-7	412-7	418-7	424-3	4424-1
7	CAPACITY DECAL (not shown)	406-1D	406-1D	406-1D	406-1D	406-1D

DIMENSIONS AND PARTS LIST

8,000 LB Capacity Hook Sheaves Models 812, 818, 824, 836

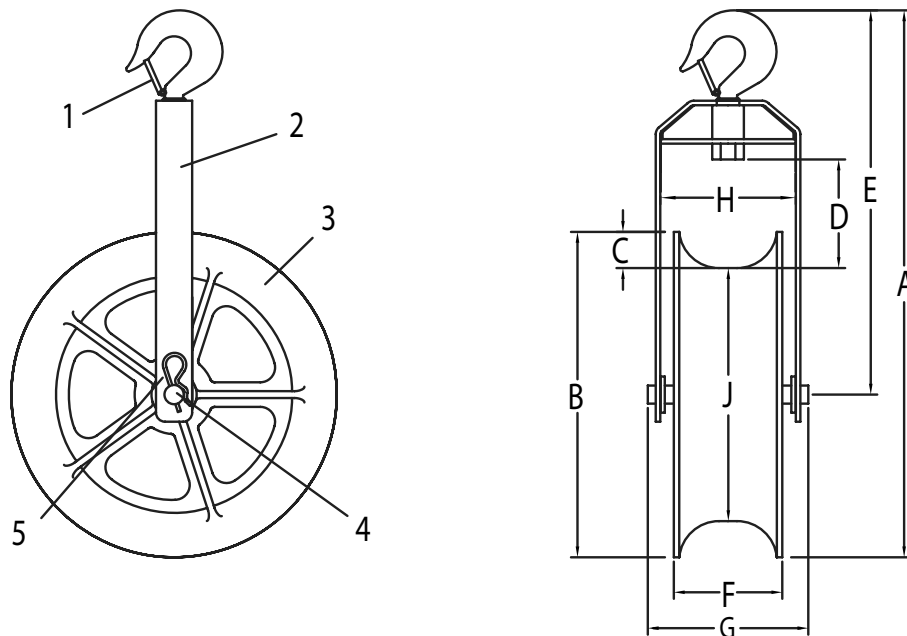

DIMENSIONAL CHART

	MODEL NUMBERS			
	812	818	824	836
A	22.18	30.26	36.51	48.51
B	10.63	18.00	24.00	36.00
C	2.25	2.00	2.13	2.13
D	5.58	6.00	6.39	6.39
E	16.88	21.26	24.51	30.51
F	5.00	6.00	6.50	6.81
G	7.38	8.50	9.00	9.38
H	6.00	7.00	7.50	8.00
J	6.13	14.00	19.75	31.75
WEIGHT LBS	24	46	69	101

ALL DIMENSIONS IN INCHES

PARTS LIST

ITEM	DESCRIPTION	MODEL NUMBERS			
		812	818	824	836
1	LATCH KIT	333-5-1A1	333-5-1A1	333-5-1A1	333-5-1A1
2	YOKE FRAME	812-587	818-586	824-585	836-589
3	SHEAVE	812-15	818-11	824-9	836-1
4	PIN-SHEAVE	812-487	818-487	824-487	836-611
5	SPRING CLIP	406-3	406-3	406-3	406-3
6	MODEL NO. DECAL (not shown)	812-5	818-2	824-2	836-2