

ES Series Hydraulic Cylinders

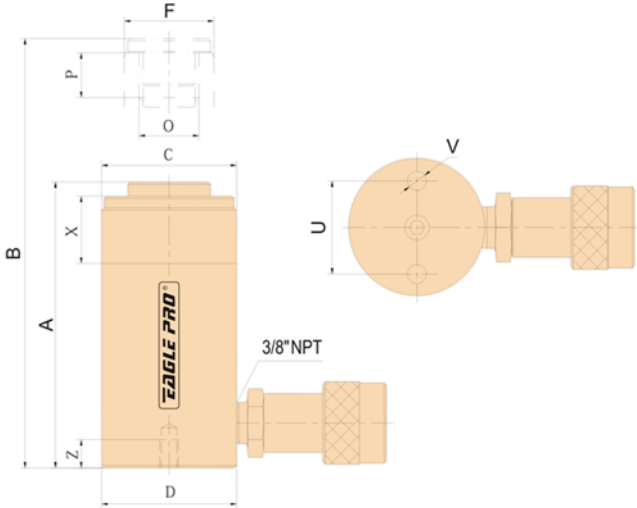

Imperial Measurements

MODEL	CYLINDER CAPACITY @ 10,000 PSI (700 BAR)	STROKE	CYLINDER EFFECTIVE AREA	OIL CAPACITY	COLLAPSED	EXTENDED	COLLAR	COLLAR	OUTSIDE	PISTON	PISTON	PISTON	BASE FIXTURING HOLES			WEIGHT										
					HEIGHT	HEIGHT	THREAD	THREAD					DIAMETER	DIAMETER	DIAMETER		BOLT	THREAD	THREAD							
					A	B	C	X					D	F	O		P	U	V	Z						
METRIC TON (US TON)		IN	IN2	IN3	IN	IN	IN	IN	IN	IN	IN	IN	IN	IN	IN	LBS										
ES-50	5 (5.5)	0.63	1.10	0.70	1.65	2.28	-	-	2.32 x 1.65	0.98	3/4 - 16UNF	0.63	0.98	1/4 - 20UNC	0.55	1.80										
ES-51		0.98		1.09	4.33	5.31	2.20																			
ES-53		2.95		3.25	6.50	9.45	2.90																			
ES-55		5.00		5.50	8.46	13.46	3.70																			
ES-57		6.97		7.67	10.75	17.72	4.60																			
ES-59		9.13		10.05	12.72	21.85	5.10																			
ES-101	10 (11)	1.02	2.25	2.30	3.50	4.53	2-1/4 - 14	1.02	2.25	1.50	10 - 24UNC	0.24	1.54	5/16 - 18UNC	0.47	3.70										
ES-102		2.13		4.78	4.76	6.89										4.80										
ES-104		4.13		9.29	6.73	10.87										6.40										
ES-106		6.14		13.80	9.72	15.87										9.00										
ES-108		7.99		17.96	11.73	19.72										10.80										
ES-1010		10.12		22.73	13.74	23.86										12.30										
ES-1012		11.97		26.89	15.75	27.72										14.10										
ES-1014		14.02		31.49	17.72	31.73										15.80										
ES-151		0.98		3.23	4.88	5.87										7.00										
ES-152		2.01		6.60	5.87	7.87										8.10										
ES-154	3.98	13.06	7.87	11.85	11.00																					
ES-156	5.98	19.66	10.67	16.65	14.30																					
ES-158	7.99	26.25	12.68	20.67	16.90																					
ES-1510	10.00	32.85	14.69	24.68	19.10																					
ES-1512	12.01	39.44	16.65	28.66	21.60																					
ES-1514	14.02	46.04	18.66	32.68	23.80																					
ES-251	25 (27.5)	1.02	5.15	5.27	5.47	6.50	3-5/16 - 12	2.13	3.39	2.24	1-1/2 - 16UNF	1.02	2.28	1/2 - 13UNC	0.75	11.70										
ES-252		1.97		10.13	6.50	8.46										13.60										
ES-254		4.02		20.66	8.46	12.48										17.60										
ES-256		6.22		32.00	10.75	16.97										22.70										
ES-258		8.27		42.53	12.72	20.98										26.60										
ES-2510		10.28		52.86	14.72	25.00										31.00										
ES-2512		12.24		62.98	16.73	28.98										34.10										
ES-2514		14.25		73.31	18.74	32.99										38.30										
ES-308		30 (33)		8.23	6.85	56.35										15.24	23.46	1.97	4.13	-	-	-	-	-	-	47.30
ES-502		50 (55)		2.01	10.99	22.06										6.93	8.94	5 - 12	2.17	5.00	3.15	-	-	3.74	1/2 - 13UNC	0.75
ES-504	4.02		44.11	8.94		12.95	39.80																			
ES-506	6.26		68.77	11.10		17.36	48.80																			
ES-5013	13.27		145.75	18.11		31.38	75.50																			
ES-756	75 (82.5)	6.14	16.10	98.87	11.22	17.36	5-3/4 - 12	1.77	5.75	3.74	-	-	-	-	-	671.00										
ES-7513		13.11		211.05	19.37	32.48										110.70										
ES-1006	95 (102.3)	6.61	20.62	136.30	14.06	20.67	6-7/8 - 12	1.73	6.97	4.13	-	-	5.47	3/4 - 10UNC	0.98	131.30										
ES-10010		10.24		210.94	17.68	27.91										160.40										

ES Series Hydraulic Cylinders

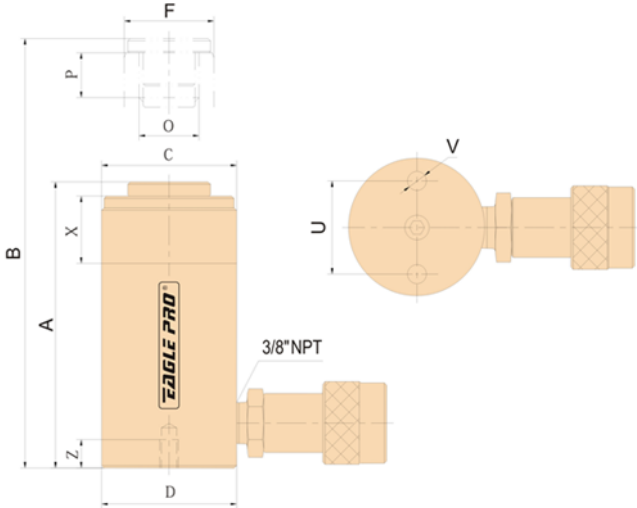

Metric Measurements

Model	CYLINDER CAPACITY @ 10,000 PSI (700 BAR)	STROKE	CYLINDER EFFECTIVE AREA	OIL CAPACITY	COLLAPSED HEIGHT	EXTENDED HEIGHT	COLLAR THREAD	COLLAR THREAD LENGTH	OUTSIDE DIAMETER	PISTON DIAMETER	PISTON INTERNAL THREAD	PISTON THREAD LENGTH	BASE FIXTURING HOLES			WEIGHT
					A	B	C	X	D	F	O	P	U	V	Z	
					MM	MM	IN	MM	MM	MM	IN	MM	MM	MM	MM	
ES-50	5 (5.5)	16	7.10	11.40	42.00	58.00	-	-	25	25	3/4 - 16UNF	16	25	1/4 - 20UNC	14	0.8
ES-51		25		17.80	110.00	135.00	1									
ES-53		75		53.30	165.00	240.00	1.3									
ES-55		127		90.20	215.00	342.00	1.7									
ES-57		177		125.70	273.00	450.00	2.1									
ES-59		232		164.70	323.00	555.00	2.3									
ES-101	10 (11)	26	14.50	37.70	89.00	115.00	2-1/4 - 14	26	57	38	19	39	5/16 - 18UNC	12	1.7	
ES-102		54		78.30	121.00	175.00									2.2	
ES-104		105		152.25	171.00	276.00									2.9	
ES-106		156		226.20	247.00	403.00									4.1	
ES-108		203		294.35	298.00	501.00									4.9	
ES-1010		257		372.65	349.00	606.00									5.6	
ES-1012	304	440.80	400.00	704.00	6.4											
ES-1014	356	516.20	450.00	806.00	7.2											
ES-151	15 (16.5)	25	21.20	53.00	124.00	149.00	2-3/4 - 16	35	70	42	25	47	3/8 - 16UNC	19	3.2	
ES-152		51		108.12	149.00	200.00									3.7	
ES-154		101		214.12	200.00	301.00									5	
ES-156		152		322.24	271.00	423.00									6.5	
ES-158		203		430.36	322.00	525.00									7.7	
ES-1510		254		538.48	373.00	627.00									8.7	
ES-1512	305	646.60	423.00	728.00	9.8											
ES-1514	356	754.72	474.00	830.00	10.8											
ES-251	25 (27.5)	26	33.20	86.32	139.00	165.00	3-5/16 - 12	54	86	57	26	58	1/2 - 13UNC	19	5.3	
ES-252		50		166.00	165.00	215.00									6.2	
ES-254		102		338.64	215.00	317.00									8	
ES-256		158		524.56	273.00	431.00									10.3	
ES-258		210		697.20	323.00	533.00									12.1	
ES-2510		261		866.52	374.00	635.00									14.1	
ES-2512	311	1032.52	425.00	736.00	15.5											
ES-2514	362	1201.84	476.00	838.00	17.4											
ES-308	30 (33)	209	44.20	923.78	387.00	596.00	5 - 12	55	127	80	95	1/2 - 13UNC	19	21.5		
ES-502	51	361.59	176.00	227.00	14.4											
ES-504	102	723.18	227.00	329.00	18.1											
ES-506	159	1127.31	282.00	441.00	22.2											
ES-5013	337	2389.33	460.00	797.00	34.3											
ES-756	156	1620.84	285.00	441.00	30.5											
ES-7513	333	3459.87	492.00	825.00	50.3											
ES-1006	95 (102.3)	168	133.00	2234.40	357.00	525.00	6-7/8 - 12	44	177	105	-	-	139	3/4 - 10UNC	25	59.7
ES-10010		260		3458.00	449.00	709.00										72.9