



MAB 1300

Large holes – up to 5 1/8" diameter
Tapping up to 1 5/8" diameter



4 Gears with Variable Speed

Powerful • Reliable

- 20 Amp double-insulated motor
- 22" high, 112 lbs.
- 4-speed oilbath gearbox for applications requiring high power
- Designed for continuous use
- Infinitely variable torque control and full-wave control electronics

Drill up to 5-1/8" dia.
Tap up to 1-5/8" dia.

- Uses annular cutters 7/16" to 5-1/8" dia., 1" and 2" depth 7/16" to 5-1/8" dia., 3" to 8" depth*
- Twist drilling up to 1-3/4" - uses MT4, countersinking up to 3" dia.
- Tapping up to 1-5/8"
- Reaming up to 2"
- Automatic internal lubrication

Integrated Safety

- Green/Red LED magnetic force indicator for safe operation
- Equipped with Electronic Safety Shutoff Sensor
- Emergency-off function

Ideal for use with TCT Carbide cutters up to 5 1/8" dia. – see pages 60-61.



* 3" depth cutters or longer require purchase of ZIA 432 KN adapter.



Equipped with Electronic Safety Shutoff Sensor
 (see p. 25)



Twist Drilling



Tapping



Reaming



Countersinking



Optional Special-Purpose Cutting Tool

Cutter Capacity	Twist Drill / Countersink	Ream / Tap	Stroke (length)	4-gear Variable Speed (RPM)	Electronics	Overheat Protection	Magnet Force Indicator	Reversible (CW/CCW)
$\varnothing 5\frac{1}{8}"$	$\varnothing 1\frac{3}{4}" / \varnothing 3"$	$\varnothing 2" / \varnothing 1\frac{5}{8}"$	3.35" (12" without retainer)	30-80 50-120 130-350 210-550	min ⁻¹ Variable-speed Control	STOP °F CoolMag™	SafeMag™	

➤ Annular Cutters: pages 54-64 ➤ Accessories: pages 65-71

MAB 1300 Specifications

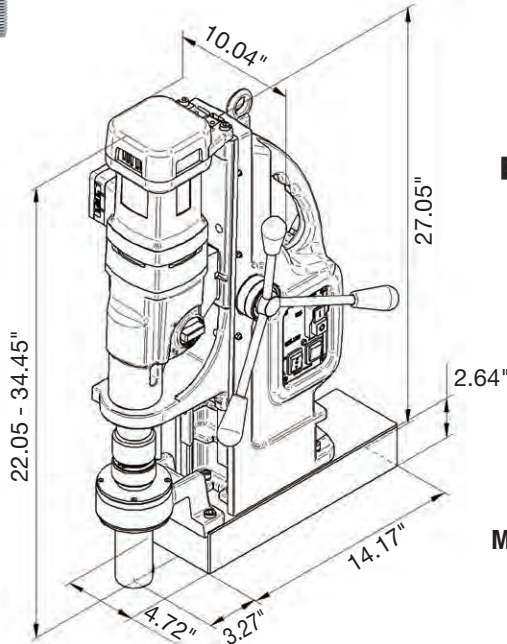

Model MAB 1300



Model MAB 1300 Specifications

Motor Power	20 Amp / 110 Volt
Weight	112 lbs.
Hole Capacity	5 1/8" dia.**
Twist Drill Capacity	1 3/4" dia.
Tapping Capacity	1 5/8" dia.
Speed	30-80, 50-120, 130-350, 210-550 RPM
Magnet Base Size	14" L x 4 3/4" W
Dimensions	22" H x 19 1/2" L x 10" W
Magnetic Force (1" plate)	23,600 lbs.
Arbor Bore	1 1/4" (3/4" adapter included)
Spindle	MT4
Automatic Lubrication	Included



** Maximum hole diameter is with TCT Carbide cutters - see p. 60-61

Standard Equipment

- 1 Magnetic drilling machine
- 1 Carrying case on wheels
- 1 Arbor adapter to 3/4" Weldon
- 1 Safety chain
- 1 Hexagon socket screw key SW 6
- 1 Drift key MT4
- 1 Operating manual
- 1 Warranty certificate



Standard Equipment also includes auto lubrication, safety strap, carabin hook and allen keys.

Accessories

See pages 48-49 for tapping accessories and wheeled carrying case.



PORTABLE MAGNETIC DRILLS



MAB 1300 V

Strongest magnetic drill with adjustable automatic feed and reverse

- Ideal for production applications
- Power feed controls drill pressure to maintain optimal RPM and feed rate

Drill up to 5-1/8" dia.
Tap up to 1-5/8" dia.
Ream up to 2" dia.



Drill automatically



Drill manually

Automatic feed motor

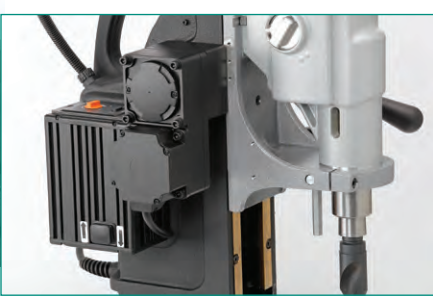

Rolling Transport Case for MAB 1300



Order No. **ZHK 1300**

Robust transport case with wheels, carrying handle and sturdy closures. Protect your investment from water and dust with this rugged case. Four large ABS locks and an interior configuration customized for machine to secure drill and accessories during transit. Lightweight, heavy-duty plastic construction and robust ABS wheels.

Drill not included with ZHK 1300. Purchase of MAB 1300 drill includes ZHK 1300 case. See page 45 for MAB 825/845 case.



Watertight, shock-proof and robust – the right protection for your machine.

Four large ABS locks secure the robust plastic case

Tapping Accessories for MAB 1300, MAB 825, MAB 845 and CSU 100/3RL



Heavy-duty Tap Holders

- Positive, accurate driving of larger-sized taps
- No slippage or tap damage
- Tap shank square engages with square drive socket
- 3 set screws secure tap in holder

Order Number	Morse Taper	Tap Size	Tap Shank Diameter	Tap Shank Square
70308	3	5/8"	.480	.366
70301	3	3/4"	.590	.442
70302	3	7/8"	.697	.523
70303	3	1"	.800	.600
70304	3	1-1/8"	.896	.672
70305	3	1-1/4"	1.02	.765
70307	3	1-1/2"	1.23	.925
70401	4	3/4"	.590	.442
70402	4	7/8"	.697	.523
70403	4	1"	.800	.600
70404	4	1-1/8"	.896	.672
70405	4	1-1/4"	1.021	.766
70406	4	1-3/8"	1.108	.831
70407	4	1-1/2"	1.233	.925
70408	4	1-5/8"	1.305	.979



Part No. **GSW 444** quick-change tapping chuck with MT4 connection (for MAB 1300). Collets not included. *GSW 444 and GSS.4xx collet set shown below.*

Order Number	Tap Collet	Shank Diameter	Square Drive
GSS.420	20mm	16mm	12mm
GSS.422	22mm	18mm	14.5mm
GSS.427	27mm	20mm	16mm
GSS.433	33mm	32mm	20mm
GSS.442	42mm	32mm	24mm



See page 68 for additional tapping options.



Tap Collets and Reducing Adapters

Tap Collets with 3/4" or 1-1/4" Weldon shank <i>all threads shown are ASA Standard (or DIN 376 for metric)</i>			
Thread	Order No.	Thread	Order No.
1/4	TCM 1/4	10mm	ZGA 010
5/16	TCM 5/16	12mm	ZGA 012
3/8	TCM 3/8	14mm	ZGA 014
7/16	TCM 7/16	16mm	ZGA 016
1/2	TCM 1/2	18mm	ZGA 018
9/16	TCM 9/16	20mm	ZGA 020
5/8	TCM 5/8	22mm	ZGA 022
11/16	TCM 11/16	24mm	ZGA 024
3/4	TCM 3/4	27mm	ZGA 027
1-1/4" Weldon shank:		1-1/4" Weldon shank:	
1	TCM 1	33mm	ZGA 033
1-1/4	TCM 1-1/4	42mm	ZGA 044

Bushing – Reduces 1-1/4" Weldon shank to 3/4" Weldon shank
Order No. **ZAP 200**



Reducing Sleeves
DIN 2185



Order No. **ZRH 320** for MT 3:2
(adapts MT3 to MT2)

Order No. **ZRH 430** for MT 4:3
(adapts MT4 to MT3)

Unibroach® Large-Hole Cutting

Cut holes up to 5-1/8" dia., 12" deep!

Available in TCT Carbide, HSS, Cobalt and ARMOR-PLATED Unibroach™



Drill perfect holes up to 5 1/8" diameter without runout

- Standard with 3/4" or 1 1/4" shank diameters
- More cutting teeth to distribute the load evenly – increase tool life and achieve faster feed rates
- Use on milling machines, drill presses, CNC and other equipment
- A solid slug has a higher value for scrap metal

* Pilot pins supplied with annular cutters up to 4" DOC. Other pilot pins can be purchased separately.

